

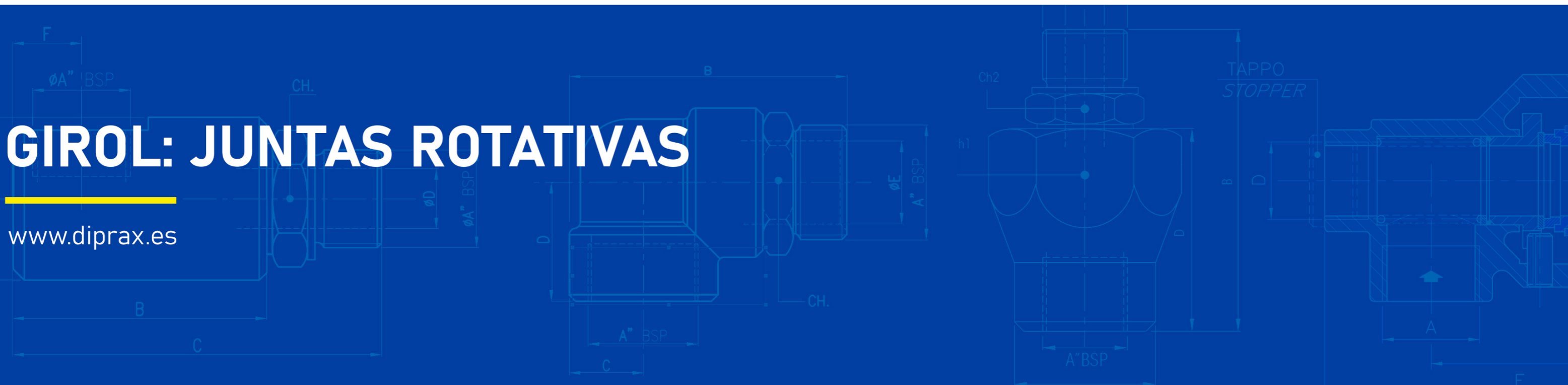

# GIROL: JUNTAS ROTATIVAS

[www.diprax.es](http://www.diprax.es)



## ABOUT US

**G**iroi srl was born on January 01 2006 from the need of its mother company OMPI srl to dedicate a closer attention to the rotating unions' development and production together with a better tailored organization of the work. In fact, the request from the markets of always more specific and customized requirements, forced the creation of an independent company having a specific sectorial identity and therefore separated from the traditional OMPI production of clutches and brakes. So it has been created the **GIROL Srl, a new firm but adult already thanks to thirty years of OMPI's experience about rotating unions.** The tech dept, organized and equipped with the most updated softwares for the design and stress calculations in 3D, is constantly involved in the research and developing of new products aimed at the international market that is getting more and more pretending. The area for the testing of the new designs and materials is managed under the direct supervision of the engineering dept., while the quality control area lets the company permanently keep the needed requested high standard quality of the current production. A fully provided warehouse allows us to satisfy the most urgent customer's requests on all our standard production letting us to be considered as a kind of rotating unions supermarket.

## CHI SIAMO

**G**iroi srl nasce il 1° Gennaio 2006 da una scissione dalla casa madre OMPI srl, produttrice di freni frizioni e giunti rotanti dal 1976. Detta scissione è stata dettata dalla necessità di dedicare alla progettazione e produzione di giunti rotanti una attenzione più specifica e una migliore organizzazione del lavoro. Infatti la richiesta da parte del mercato di prodotti sempre più diversificati e personalizzati ha imposto la creazione di un'azienda autonoma, avente una identità specifica settoriale e quindi scorporata dalla tradizionale produzione OMPI di freni e frizioni. È nata così la **GIROL Srl, un'azienda nuova ma al tempo stesso già adulta perchè forte della trentennale esperienza di OMPI srl nel settore dei giunti rotanti.** L'ufficio tecnico, organizzato ed attrezzato con i più moderni software per la progettazione e le verifiche di resistenza in 3D, è costantemente impegnato nella ricerca e sviluppo di nuovi prodotti volti ad un mercato che diventa sempre più esigente e diversificato. Il reparto prove è gestito in stretto contatto con l'ufficio tecnico per testare i nuovi articoli sperimentali mentre il reparto collaudi consente il mantenimento dei requisiti di qualità sulla produzione corrente. Un fornitissimo magazzino ci permette di soddisfare anche le richieste più urgenti per tutta la gamma di produzione standard, consentendoci di essere considerati dai nostri clienti un autentico supermercato del giunto rotante.

## CONTENTS // SOMMARIO

<u>06</u>	Series/Serie	U	<u>26</u>	Series/Serie	On/Off
<u>10</u>	Series/Serie	R	<u>28</u>	Series/Serie	K
<u>12</u>	Series/Serie	D	<u>32</u>	Series/Serie	M
<u>14</u>	Series/Serie	N	<u>36</u>	Series/Serie	Z
<u>18</u>	Series/Serie	HD	<u>38</u>	Series/Serie	RR
<u>20</u>	Series/Serie	IH	<u>39</u>	Series/Serie	E
<u>22</u>	Series/Serie	Y	<u>40</u>	Retailers // Rivenditori	
<u>24</u>	Series/Serie	AB	<u>42</u>	Installation // Installazione	

# U

## UNIVERSAL ROTATING UNION Giunti rotanti universali

The Girol's U series has been designed to have many different applications. It can be used not only in steel plants, but also in paper, printing, cooling, textile, rubber, food and packaging industries. We can supply these type of rotating unions in two different seals: graphite (clean water) and silicon carbide (dirty water). The standard supply consist of brass housing and stainless steel rotor. We can also provide it in mono flow or dual flow versions as follows: UM (mono flow), UF (dual flow for fixed siphon).

I giunti Girol della serie U, sono progettati per diverse applicazioni. Sono utilizzati non solo in impianti siderurgici, ma anche nell'industria cartaria, alimentare, della gomma, tessile e per tante altre applicazioni. Le tenute meccaniche sono disponibili in due differenti materiali: grafite (per acqua pulita e aria) e carburo di silicio (per acqua non filtrata o con impurità). La fornitura standard prevede come materiali costruttivi, l'ottone per il corpo e l'acciaio inox per il rotore.

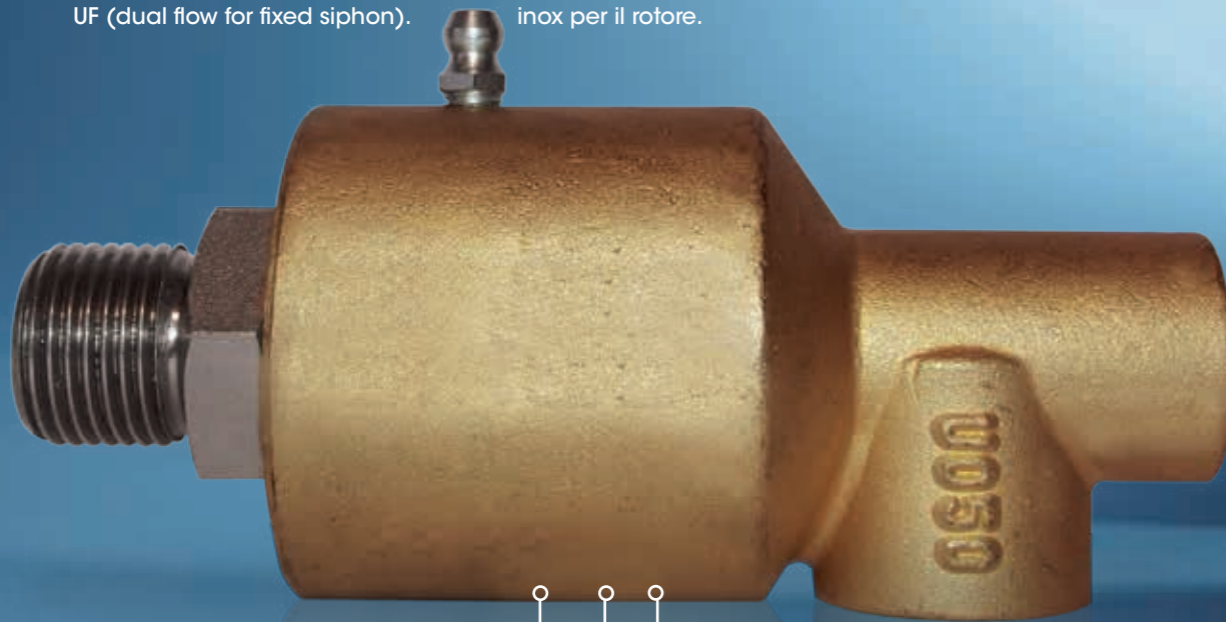

**MAX SPEED**  
► From 500 to 5.000 rpm

**MAX FLUID PRESS**  
► AIR 12 bars  
► FLUIDS 30 bars

**MAX TEMPERATURE**  
► AIR 80 °C  
► WATER · OIL · FLUIDS 110 °C

## UNIVERSAL ROTATING UNION Giunti rotanti universali

# UM

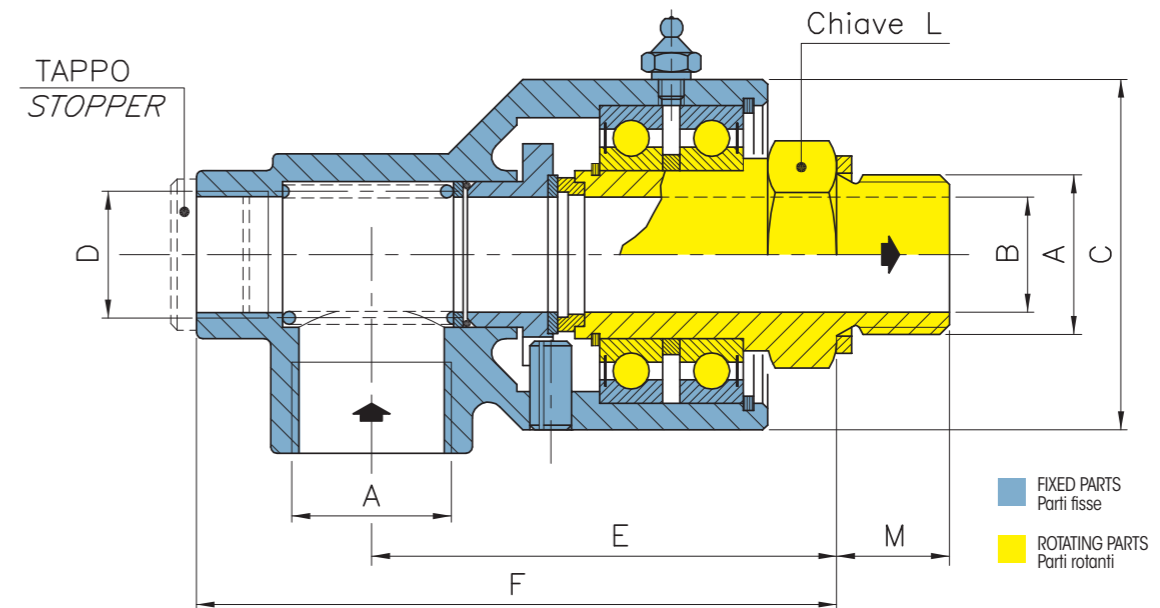

For left thread, the third letter of code change replacing "D" with "S"  
Per filettature sinistre, la terza lettera del codice varia sostituendo "D" con "S"

GRAPHITE-INOX Grafite-Inox	SILICON-SILICON Silicio-Silicio	A	B	C	D	E	F	L	M	WEIGHT peso	RPM G/min
UMD025-GB3GS	UMD025-GB2GS	1/4" BSP	6 0.236	36 1.417	/	60 2.362	74 2.914	17	14,5 0,571	0,4 Kg 0,88 lb	5.000
UMD037-GB3GS	UMD037-GB2GS	3/8" BSP	10 0.394	44 1.732	1/4" BSP	68 2.677	90 3.543	22	16 0.630	0,6 Kg 1.32 lb	3.500
UMD050-GB3GS	UMD050-GB2GS	1/2" BSP	13 0.512	52 2.047	3/8" BSP	76 2.992	101 3.976	27	18 0.709	0,8 Kg 1.76 lb	3.000
UMD075-GB3GS	UMD075-GB2GS	3/4" BSP	18 0.709	57 2.244	1/2" BSP	80 3.150	111 4.370	32	20 0.787	1,1 Kg 2.43 lb	2.500
UMD100-GB3GS	UMD100-GB2GS	1" BSP	24 0.945	73 2.874	3/4" BSP	97 3.819	134 5.276	41	23 0.906	1,9 Kg 4.19 lb	2.000
UMD125-GB3GS	UMD125-GB2GS	1 1/4" BSP	32 1.260	87 3.425	1" BSP	113 4.449	158 6.220	50	29 1.142	3,2 Kg 7.05 lb	1.500
UMD150-GB3GS	UMD150-GB2GS	1 1/2" BSP	38 1.496	94 3.701	1 1/4" BSP	117 4.606	166 6.535	55	31 1.220	3,9 Kg 8.60 lb	1.000
UMD200-GB3GS	UMD200-GB2GS	2" BSP	48 1.890	108 4.252	1 1/2" BSP	131 5.157	189 7.441	65	35 1.378	5,3 Kg 11.6 lb	800
UMD250-GC3GS	UMD250-GC2GS	2 1/2" BSP	62 2.441	140 5.512	2" BSP	200 7.874	280 11.02	75	42 1.654	13 Kg 28.6 lb	500

### General assembling warnings

- 1) Pipe connection have **always** to be made with flexible hoses
- 2) The plant pipings and the rotating cylinders must be **absolutely** cleaned from chips welding slags, dirtiness and so on
- 3) Avoid use with more than one max operatin data

### Avvertenze generali di montaggio

- 1) I collegamenti al corpo del giunto devono essere **sempre** effettuati con tubi flessibili
- 2) le tubazioni di adduzione al giunto e ai cilindri devono essere **assolutamente** esenti da trucioli, scorie di saldature o altro
- 3) Evitare l'uso con più di una condizione massima di funzionamento.

**UF**

**DUAL FLOW // FIXED SYPHON**

Due vie // Tubo sifone fisso

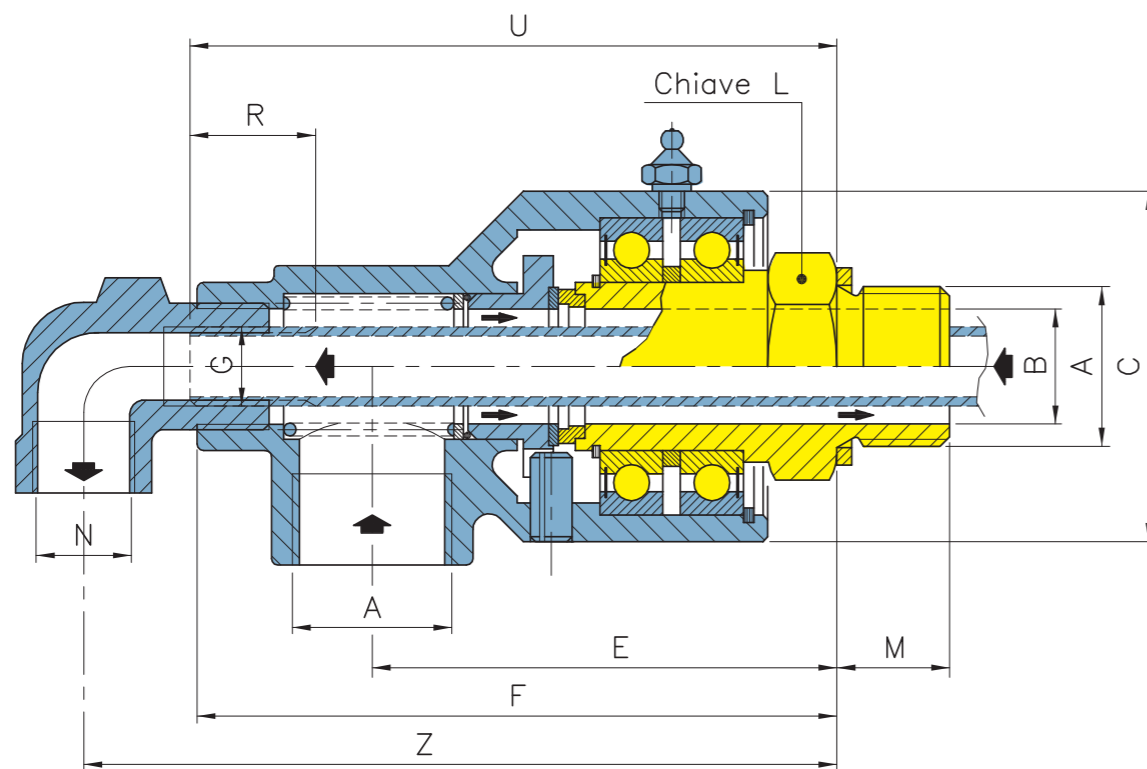

For left thread, the third letter of code change replacing "D" with "S"  
Per filettature sinistre, la terza lettera del codice varia sostituendo "D" con "S"

GRAPHITE-INOX Grafito-Inox	SILICON-SILICON Silicio-Silicio	G1 (Optional)	G	N	R	U	Z
UFD039-GB3GS	UFD039-GB2GS	/	M8	1/8" BSP	15 0,591	105 4,133	122 4,803
UFD052-GB3GS	UFD052-GB2GS	/	1,8" BSP	1/4" BSP	15 0,591	100 3,937	134 5,276
UFD077-GB3GS	UFD077-GB2GS	1/8" BSP	1/4" BSP	3/8" BSP	15 0,591	110 4,331	147 5,787
UFD102-GB3GS	UFD102-GB2GS	1/4" BSP	3/8" BSP	1/2" BSP	15 0,591	130 5,118	174 6,850
UFD127-GB3GS	UFD127-GB2GS	3/8" BSP	1/2" BSP	3/4" BSP	25 0,984	155 6,102	203 7,992
UFD152-GB3GS	UFD152-GB2GS	1/2" BSP	3/4" BSP	1" BSP	25 0,984	165 6,495	222 8,740
UFD202-GB3GS	UFD202-GB2GS	3/4" BSP	1" BSP	1" 1/4 BSP	25 0,984	185 7,283	248 9,764
UFD252-GC3GS	UFD252-GC2GS	1" BSP	1" 1/4 BSP	1" 1/2 BSP	30 1,181	280 11,02	348 13,70

**Threaded pipe**

The elbow of UF series help to support the siphon and it will be screwed in the elbow. The thread must be concentric of rotating union's axis for avoid misalignment

**Tubo filettato**

La curva dei giunti serie UF fa da supporto al tubo sifone, il quale si avvita su di essa. Il filetto deve essere concentrico all'asse del giunto per evitare disassamenti rispetto all'asse del rullo

**UR**

**ROTATING SYPHON**

Tubo sifone rotante

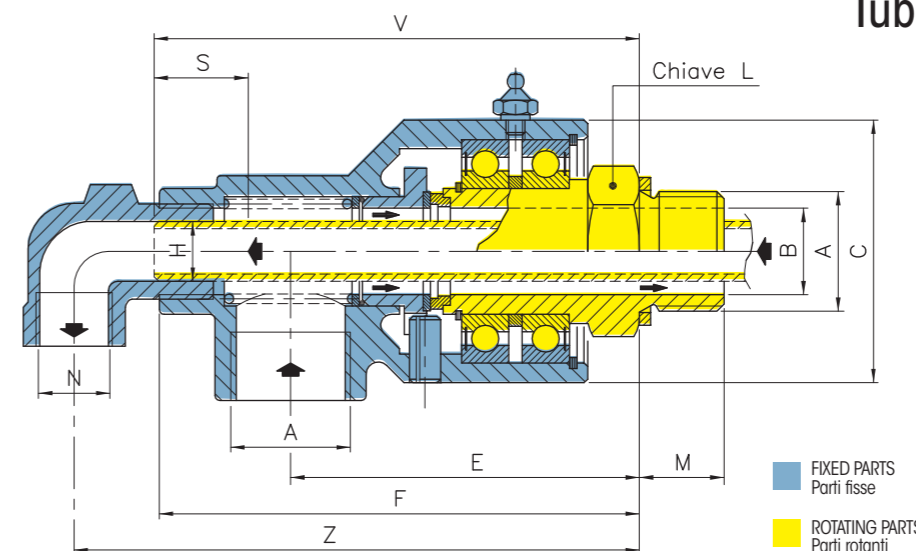

For left thread, the third letter of code change replacing "D" with "S"  
Per filettature sinistre, la terza lettera del codice varia sostituendo "D" con "S"

GRAPHITE-INOX Grafito-Inox	SILICON-SILICON Silicio-Silicio	H	S	V
URD039-GB3GS	URD039-GB2GS	6 0,263	40 1,575	95 3,740
URD052-GB3GS	URD052-GB2GS	9 0,354	40 1,575	105 4,133
URD077-GB3GS	URD077-GB2GS	12 0,472	50 1,969	115 4,527
URD102-GB3GS	URD102-GB2GS	16 0,630	50 1,969	165 5,496
URD127-GB3GS	URD127-GB2GS	20 0,787	60 2,362	190 7,480
URD152-GB3GS	URD152-GB2GS	25 0,984	60 2,362	200 7,874
URD202-GB3GS	URD202-GB2GS	32 1,260	60 2,362	222 8,898
URD252-GC3GS	URD252-GC2GS	40 1,575	60 2,362	320 12,98

**Turning pipe**

Rotating siphon are fixed internally with the roll for rotating with it. The UR elbow help to support the pipe and restrict crosstalk passages. The pipe must be straight and concentric to the center line to avoid excessive loading of the union. Rotational speeds above 1.000 rpm should be avoided.

**Tubo tornito**

I tubi rotanti sono fissati internamente al rullo per ruotare insieme con esso. La curva UR fa da supporto al sifone, il quale deve essere concentrico all'asse del giunto per evitare carichi eccessivi su di esso. Una rotazione superiore a 1.000 g/min è da evitare

**UT**

**ROTATING SYPHON**  
Tubo sifone rotante con tenuta

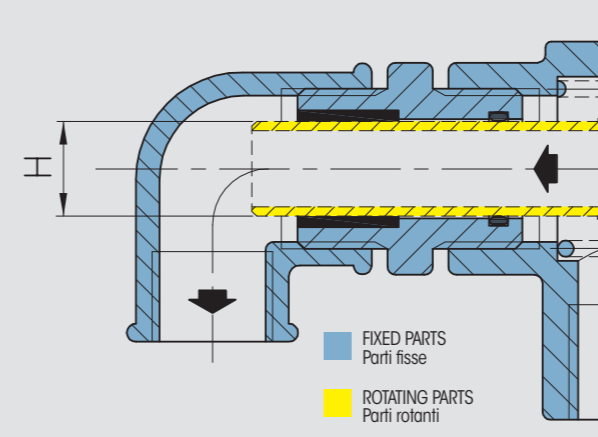

For UT series it's the same for UR series, but in the elbow there is one seal for double independent passage

Per la serie UT vale lo stesso discorso della serie UR, ma con la differenza che nella curva è presente una guarnizione che consente di avere due vie indipendenti.

# R

## ROTATING UNION FOR AIR AND VACUUM // HIGH SPEEDNESS

Giunti rotanti per aria e vuoto // Alta velocità

The rotating unions GIROL series R are designed for air and vacuum and high speed rotation. The seal are made C 45 hardened and ground vs graphite bush for low friction and long lasting. They are self supported on ball bearings. The housing material is made in aluminum. The standard supply provides the rotating nipple threaded cylindrical GAS right or left. On the request we supply other standard.

I giunti rotanti della serie R comprendono il rotore con filettatura cilindrica GAS destra o sinistra. Sono progettati per aria o vuoto per alte velocità di rotazione. Le tenute in C 45 temprato e rettificato su grafite garantiscono bassa usura e lunga durata. Sono autosupportati su cuscinetti a sfera. Il materiale del corpo è in alluminio. Su richiesta si eseguono versioni speciali con rotor filettati secondo altri standard.

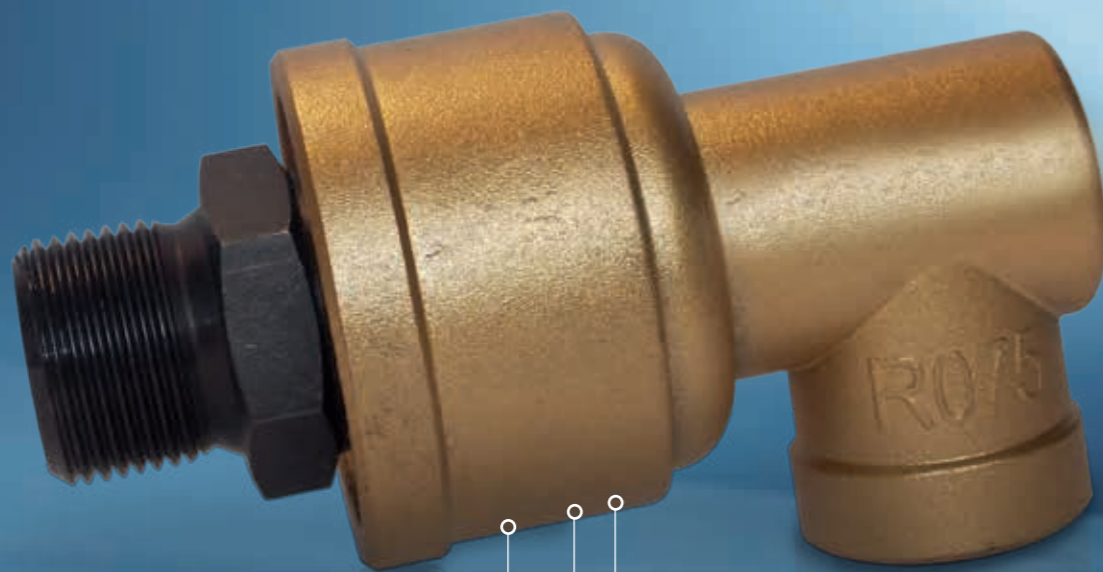

**MAX SPEED**

► From 500 to 3.000 rpm

**MAX FLUID PRESS**

► AIR 10,5 bars  
► VACUUM 700 mm/hg

**MAX TEMPERATURE**

► AIR 80 °C

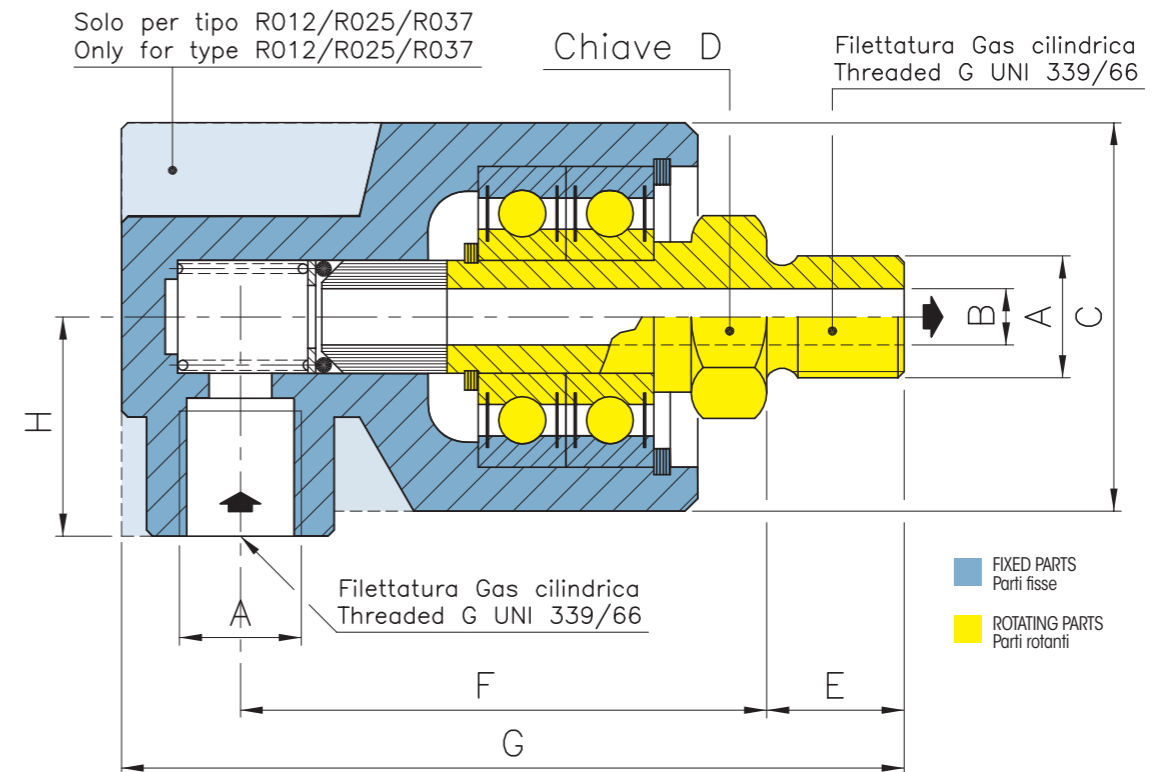

For left thread, the third letter of code change replacing "D" with "S"  
Per filettature sinistre, la terza lettera del codice varia sostituendo "D" con "S"

CODE Codice	A	B	C	D	E	F	G	H	WEIGHT peso	RPM g/min
RMD012-GB4GR	1/8" BSP	4,5 0,177	35 1,378	14	11 0,433	42 1,654	63 2,480	15 0,591	0,2 Kg 0,5 lb	3.000
RMD025-GB4GR	1/4" BSP	7 0,276	40 1,575	17	14,5 0,571	50 1,969	76 2,992	17,5 0,689	0,3 kg 0,66 lb	2.500
RMD037-GB4GR	3/8" BSP	10 0,394	48 1,890	22	16 0,630	60 2,362	90 3,543	20,5 0,807	0,43 kg 0,95 lb	2.000
RMD050-GB4GR	1/2" BSP	12,5 0,492	50 1,969	27	18 0,709	80 3,150	111 4,370	30 1,181	0,75 kg 1,65 lb	1.500
RMD075-GB4GR	3/4" BSP	17 0,669	56 2,205	32	20 0,787	86 3,386	122 4,803	36 1,417	0,96 kg 2,12 lb	1.000
RMD100-GB4GR	1" BSP	22 0,866	65 2,559	41	23,5 0,925	98 3,858	138 5,433	40 1,575	1,4 kg 3,09 lb	500
RMD125-GB4GR	1" 1/4 BSP	32 1,253	90 3,543	50	29 1,141	108 4,251	169 6,471	53 2,086	1,9 kg 4,19 lb	500
RMD150-GB4GR	1" 1/2 BSP	38 1,496	95 3,740	55	31 1,220	117 4,606	183 7,204	58 2,283	2,2 kg 4,85 lb	500

**General assembling warnings**

- 1) Pipe connection have **always** to be made with flexible hoses
- 2) The plant pipings and the rotating cylinders must be **absolutely** cleaned from chips welding slags, dirtiness and so on
- 3) Avoid use with more than one max operatin data

**Avvertenze generali di montaggio**

- 1) I collegamenti al corpo del giunto devono essere **sempre** effettuati con tubi flessibili
- 2) le tubazioni di adduzione al giunto e ai cilindri devono essere **assolutamente** esenti da trucioli, scorie di saldature o altro
- 3) Evitare l'uso con più di una condizione massima di funzionamento.

D

## DUAL FLOW INDEPENDENT ROTATING UNION Giunti rotanti doppio passaggio indipendente

The standard supply provides the rotating nipple threaded cylindrical GAS. On the request we supply other standard. Standard seal (graphite vs. stainless steel) is used for air and for water or hydraulic oil, seal of silicon carbide vs. silicon carbide is suggested. For liquid at pressure more than 60 bar (870 PSI) please contact our technician

La fornitura standard comprende il rotore con filettatura cilindrica GAS. Su richiesta forniamo rotori filettati secondo altri standard. La tenuta standard (grafite su acciaio Inox) si utilizza per aria e per acqua con filtraggio pari ad almeno 20 micron. Per liquidi con pressioni superiori a 60 bar si consiglia di consultare un nostro tecnico.

### MAX FLUID PRESS

- ▶ AIR 1°-12 bars, 2°-6 bars
- ▶ LIQUID 1°-70 bars, 2°-12 bars



### MAX SPEED

- ▶ AIR · WATER · OIL · FLUIDS  
From 500 to 5.000 rpm

### MAX TEMPERATURE

- ▶ AIR 80° C / 176° F
- ▶ LIQUID 110° C / 230° F

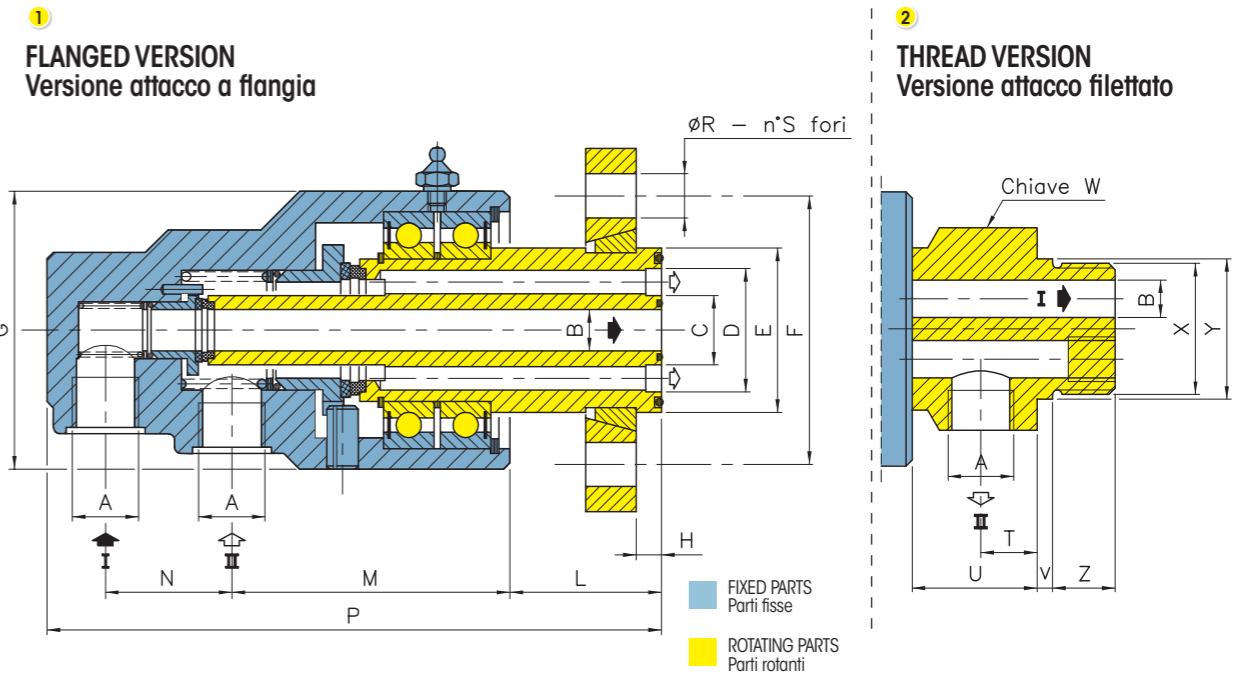

### 1 FLANGED VERSION

GRAPHITE-INOX Grafite-Inox	SILICON-SILICON Silicio-Silicio	A	B	C	D	E	F	G	H	L	M	N	P	R	S
D-0025-GY3LS	D-0025-GY2LS	1/4" BSP	6 0.236	12.5 0.492	22 0.866	36 1.417	65 2.559	60 2.362	6 0.236	43 1.693	62 2.441	30 1.181	148 5.827	14 0.551	4
D-0037-GY3LS	D-0037-GY2LS	3/8" BSP	10 0.394	17 0.669	30 1.181	45 1.772	75 2.953	75 2.953	8 0.315	48 1.890	78 3.071	38 1.496	178 7.008	14 0.551	4
D-0050-GY3LS	D-0050-GY2LS	1/2" BSP	13 0.512	22 0.866	39 1.535	52 2.047	85 3.346	88 3.465	8 0.315	48 1.890	88 3.465	40 1.575	194 7.638	14 0.551	4
D-0075-GY3LS	D-0075-GY2LS	3/4" BSP	18 0.709	26 1.024	44 1.732	58 2.283	100 3.937	94 3.701	10 0.394	57 2.244	93 3.661	48 1.890	224 8.819	18 0.709	4
D-0100-GY3LS	D-0100-GY2LS	1" BSP	24 0.945	33 1.299	53 2.087	65 2.559	100 3.937	110 4.331	10 0.394	57 2.244	100 3.937	58 2.283	246 9.685	18 0.709	4

### 2 THREAD VERSION

GRAPHITE-INOX Grafite-Inox	SILICON-SILICON Silicio-Silicio	A	B	T	U	V	Z	W	X	RPM G/min
D-D025-GY3GS	D-D025-GY2GS	1/4" BSP	6 0.236	11 0.433	23 0.906	4 0.157	14 0.551	36	3/4" BSP	2.800
D-D037-GY3GS	D-D037-GY2GS	3/8" BSP	10 0.394	13 0.512	30 1.181	4 0.157	18 0.709	55	1" BSP	2.100
D-D050-GY3GS	D-D050-GY2GS	1/2" BSP	13 0.512	18 0.709	40 1.575	5 0.197	22 0.866	65	1 1/4" BSP	1.700
D-D075-GY3GS	D-D075-GY2GS	3/4" BSP	18 0.709	21 0.827	51 2.008	6 0.236	25 0.984	70	1 1/2" BSP	1.500
D-D100-GY3GS	D-D100-GY2GS	1" BSP	24 0.945	25 0.984	56 2.205	8 0.315	28 1.102	90	2" BSP	1.200

For left thread, the third letter of code change replacing "D" with "S"  
Per filettature sinistre, la terza lettera del codice varia sostituendo "D" con "S"

# N

## ROTATING UNION FOR STEAM OR HOT OIL Giunti rotanti per vapore o olio diatermico

The GIROL N series is divided into two categories:

• **FOR STEAM:** The rotary part and flange are made of stainless steel.

**FOR HOT OIL:** The entire rotary union is made of cast iron.

For both categories, the seal and bearings are made with impregnated graphite.

The housing, a fixed part, has cylindrical BSP thread while the shaft, the rotary part, has conical BSP thread.

I giunti GIROL della serie N si suddividono in due categorie:

• **PER VAPORE:** la fornitura standard prevede che la parte rotante e la flangia di chiusura siano in acciaio inox.

• **PER OLIO DIATERMICO:** la fornitura standard prevede che il materiale costruttivo sia interamente in ghisa. Per entrambe le categorie la tenuta sferica e i cuscinetti sono in grafite impregnata, le filettature GAS cilindriche per la parte fissa (corpo) e GAS conica per la parte rotante (rotore).

### MAX FLUID PRESS

► STEAM · WATER · HOT OIL  
from 3 bar to 35 bars



### MAX SPEED

► From 5 to 400 rpm

### MAX TEMPERATURE

► STEAM · WATER · HOT OIL 316 °C

## MONOFLOW VERSION NB Versione monovia

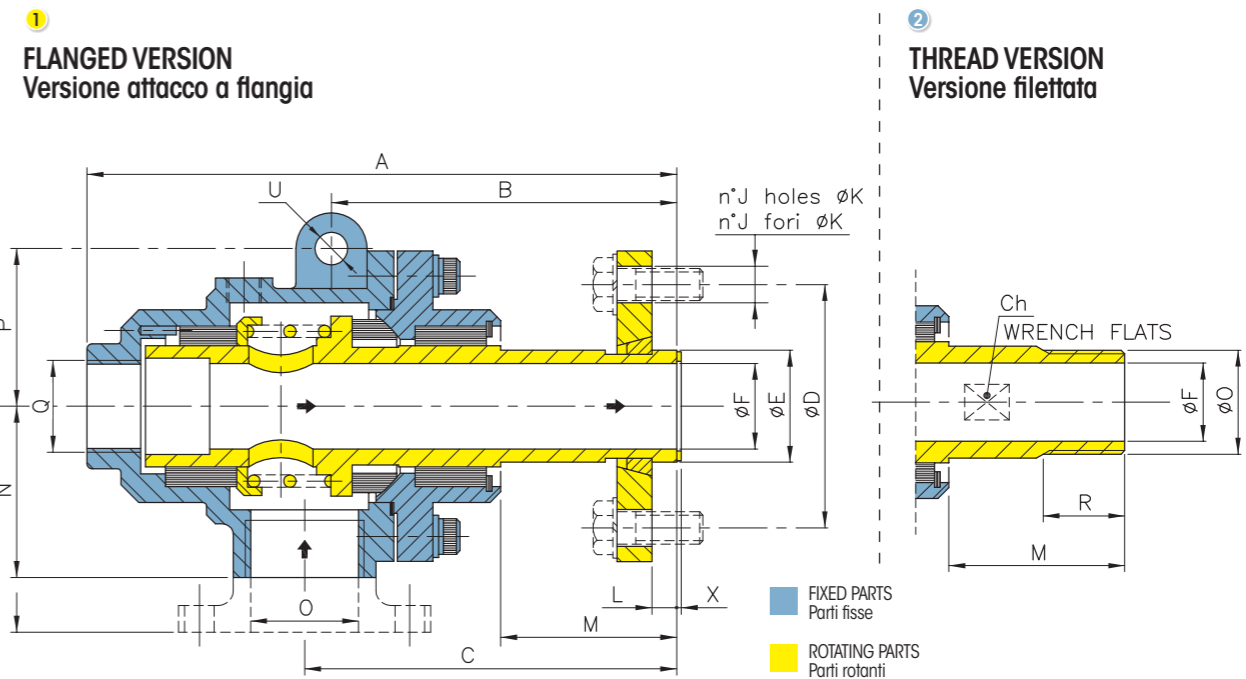

For left thread, the third letter of code change replacing "D" with "S"  
Per filettature sinistre, la terza lettera del codice varia sostituendo "D" con "S"

STEAM Vapore	HOT OIL Olio caldo	A	B	C	D	E	F	J	K	L	M	N	O	P	Q	R	Ch	U	
2	NBD037-GF3KX	NBD037-GF7KF	103	/	74,5	/	/	10	/	/	/	28 1,02	30	3/8" BSP	30	3/8" BSP	15	17	/
2	NBD050-GF3KX	NBD050-GF7KF	137	82	90	/	/	19	/	/	/	40 1,57	40	1/2" BSP	38	1/2" BSP	18	24	10
2	NBD075-GF3KX	NBD075-GF7KF	137	82	90	/	/	19	/	/	/	40	40	3/4" BSP	38	1/2" BSP	18	24	10
1	NB0075-GF3LX	NB0075-GF7LF				75	26	4	14	11	1,57								
2	NBD100-GF3KX	NBD100-GF7KF	163	99	108	/	/	24	/	/	/	49	48	1" BSP	46	3/4" BSP	18	30	12
1	NB0100-GF3LX	NB0100-GF7LF				85	32,5	4	14	11	1,92								
2	NBD125-GF3KX	NBD125-GF7KF	183	106	115	/	/	32	/	/	/	50	60	1 1/4" BSP	58	1" BSP	23	40	12
1	NB0125-GF3LX	NB0125-GF7LF				85	41,3	4	14	12,5	1,96								
2	NBD150-GF3KX	NBD150-GF7KF	200	119	134	/	/	38	/	/	/	55	63	1 1/2" BSP	60	1 1/4" BSP	24	46	14
1	NB0150-GF3LX	NB0150-GF7LF				100	47,5	4	18	12,5	2,16								
2	NBD200-GF3KX	NBD200-GF7KF	236	135	155	/	/	49	/	/	/	62	75	2" BSP	70	1 1/2" BSP	25	58	16
1	NB0200-GF3LX	NB0200-GF7LF				125	59,1	4	18	16	2,44								
2	NBD250-GF3KX	NBD250-GF7KF	271	152	175	/	/	62	/	/	/	68,5	90	2 1/2" BSP	81	2" BSP	32	73	18
1	NB0250-GF3LX	NB0250-GF7LF				125	72,2	4	18	19	2,69								
2	NBD300-GF3KX	NBD300-GF7KF	308	165	194	/	/	72	/	/	/	73	103	3" BSP	90	2 1/2" BSP	33	83	20
1	NB0300-GF3LX	NB0300-GF7LF				160	87,3	8	18	22	2,87								
1	NB0400-LF1LF		338	189	213	180	112,7	95	8	18	25	85 3,34	160	DN100	115	/	/	/	25
1	NB0500-LF1LF		417	222	257	240	139,2	122	8	22	32	96 3,78	200	DN125	140	/	/	/	30
1	NB0600-LF1LF		498	248	291	270	168	146	8	22	32	103 4,05	220	DN150	162	/	/	/	35
1	NB0800-LF1LF		673	317	363	295	/	200	12	22	60	113 4,44	250	DN200	210	/	/	/	40



NF

## DUAL-FLOW UNIONS // FIXED SYPHON TUBE

Giunti a due vie // Tubo sifone fisso

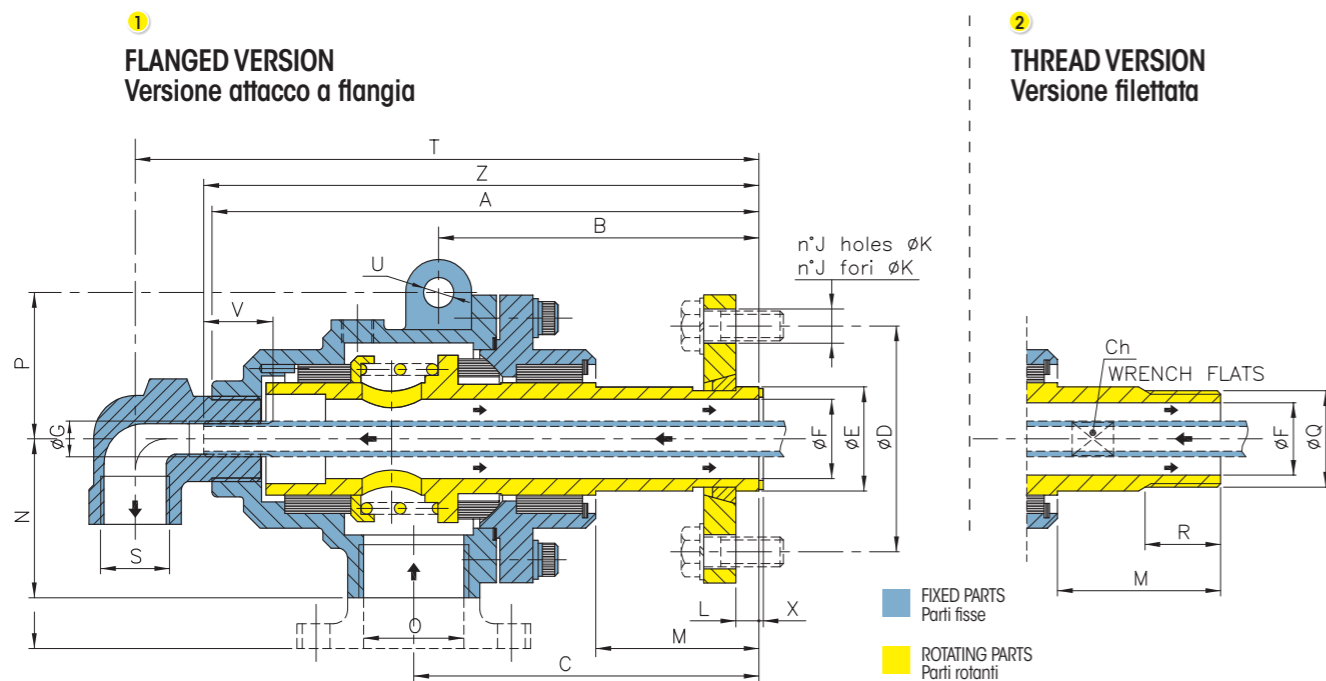

### Threaded pipe

The elbow of NF series help to support the syphon and it will be screwed in the elbow. The thread must be concentric of rotating union's axis for avoid misalignment

### Tubo filettato

La curva dei giunti serie NF fa da supporto al tubo sifone, il quale si avvita su di essa. Il filetto deve essere concentrico all'asse del giunto per evitare disassamenti rispetto all'asse del rullo

For left thread, the third letter of code change replacing "D" with "S"  
Per filettature sinistre, la terza lettera del codice varia sostituendo "D" con "S"

	STEAM Vapore	HOT OIL Olio caldo	G	G1 (opt.)	T	V	Z
②	NFD039-GF3KX	NFD039-GF7KF	M6	1/8" BSP	120	15	107
②	NFD052-GF3KX	NFD052-GF7KF	1/8" BSP	1/4" BSP	150	15	137
②	NFD077-GF3KX	NFD077-GF7KF	1/4" BSP	1/8" BSP	169	15	159
①	NF0077-GF3LX	NF0077-GF7LF					
②	NFD102-GF3KX	NFD102-GF7KF	3/8" BSP	1/4" BSP	202	17	187
①	NF0102-GF3LX	NF0102-GF7LF					
②	NFD127-GF3KX	NFD127-GF7KF	1/2" BSP	3/8" BSP	232	20	212
①	NF0127-GF3LX	NF0127-GF7LF					
②	NFD152-GF3KX	NFD152-GF7KF	3/4" BSP	1/2" BSP	256	25	231
①	NF0152-GF3LX	NF0152-GF7LF					
②	NFD202-GF3KX	NFD202-GF7KF	1" BSP	3/4" BSP	296	25	271
①	NF0202-GF3LX	NF0202-GF7LF					
②	NFD252-GF3KX	NFD252-GF7KF	1 1/4" BSP	1" BSP	337	28	307
①	NF0252-GF3LX	NF0252-GF7LF					
②	NFD302-GF3KX	NFD302-GF7KF	1 1/2" BSP	2 1/4" BSP	387	30	347
①	NF0302-GF3LX	NF0302-GF7LF					
①	NB0402-LF1LF		2" BSP	DN 65	464	35	343
①	NB0502-LF1LF		2 1/2" BSP	DN 80	567	60	420
①	NB0602-LF1LF		3" BSP	DN 100	685	70	500
①	NB0802-LF1LF		4" BSP	DN 125	723	150	615

## DUAL-FLOW UNIONS // FREELY ROTATING SYPHON TUBE

Giunti a due vie // tubo sifone rotante libero

NR

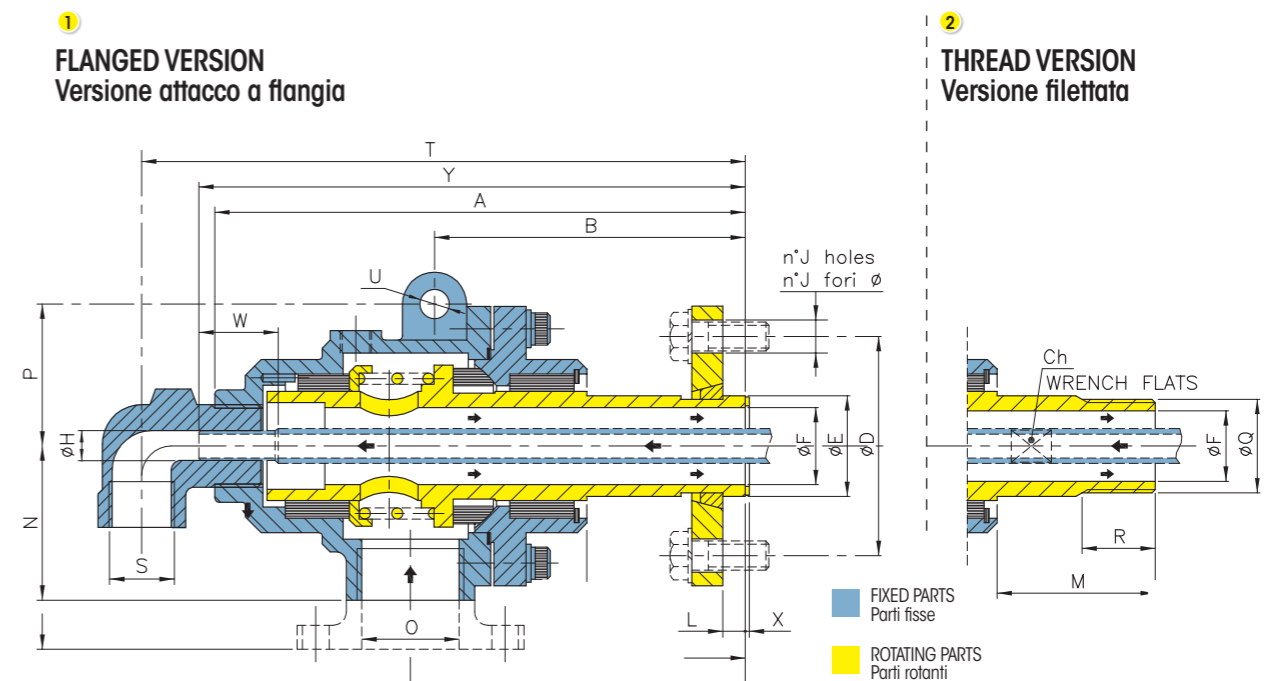

For left thread, the third letter of code change replacing "D" with "S"  
Per filettature sinistre, la terza lettera del codice varia sostituendo "D" con "S"

	STEAM Vapore	HOT OIL Olio caldo	H	S	T	V	Y
②	NRD039-GF3KX	NRD039-GF7KF	6	1/8" BSP	120	15	107
②	NRD052-GF3KX	NRD052-GF7KF	9	1/4" BSP	150	15	137
②	NRD077-GF3KX	NRD077-GF7KF	12	3/8" BSP	169	15	159
①	NR0077-GF3LX	NR0077-GF7LF					
②	NRD102-GF3KX	NRD102-GF7KF	16	1/2" BSP	202	17	187
①	NR0102-GF3LX	NR0102-GF7LF					
②	NRD127-GF3KX	NRD127-GF7KF	20	3/4" BSP	232	20	212
①	NR0127-GF3LX	NR0127-GF7LF					
②	NRD152-GF3KX	NRD152-GF7KF	25	1" BSP	256	25	231
①	NR0152-GF3LX	NR0152-GF7LF					
②	NRD202-GF3KX	NRD202-GF7KF	32	1 1/4" BSP	296	25	271
①	NR0202-GF3LX	NR0202-GF7LF					
②	NRD252-GF3KX	NRD252-GF7KF	40	1 1/2" BSP	337	28	307
①	NR0252-GF3LX	NR0252-GF7LF					
②	NRD302-GF3KX	NRD302-GF7KF	45	2" BSP	387	30	347
①	NR0302-GF3LX	NR0302-GF7LF					
①	NR0402-LF1LF		58	DN 65	464	35	343
①	NR0502-LF1LF		75	DN 80	567	60	420
①	NR0602-LF1LF		87	DN 100	685	70	500
①	NR0802-LF1LF		112	DN 125	723	150	615

## ROTARY SYPHON WITH SEAL

Tubo sifone rotante con tenuta

NT

For NT series it's the same for NR series, but in the elbow there is one seal for double independent passage

Per la serie NT vale lo stesso discorso della serie NR, ma con la differenza che nella curva è presente una guarnizione che consente di avere due vie indipendenti.

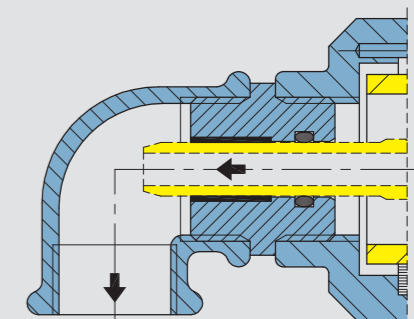

# HD

## ROTATING UNION TWO INDEPENDENT DIRECTIONS Giunti rotanti due vie indipendenti

The GIROL HD series is designed for mounting in a coil machine. However, it is a product that can be used in a variety of applications, whenever a rotary union is necessary with two directions and high pressure capability up to 350 bars. The alignment and precision are guaranteed by the use of a ball bearing. The external housing is made of aluminum while the internal rotor is made from nickel-plated carbon steel.

I giunti GIROL della serie HD sono progettati principalmente per il montaggio su ASPI, ma essendo un prodotto universale consente l'utilizzo su svariate applicazioni, dove si richiede un giunto due vie indipendenti con pressioni fino a 350 bar e qualsiasi tipo di fluido (olio idraulico, acqua, aria...). L'assialità e la precisione sono garantite dai cuscinetti a sfera. I materiali costruttivi sono, alluminio anodizzato per la parte esterna (corpo) e acciaio al carbonio trattato al niprolo per parte interna (rotore).

### MAX FLUID PRESS

▶ WATER / HYDR.OIL / AIR  
350 bars

### MAX SPEED

▶ From 100 to 120 rpm

### MAX TEMPERATURE

▶ WATER / HYDR.OIL / AIR 120 °C

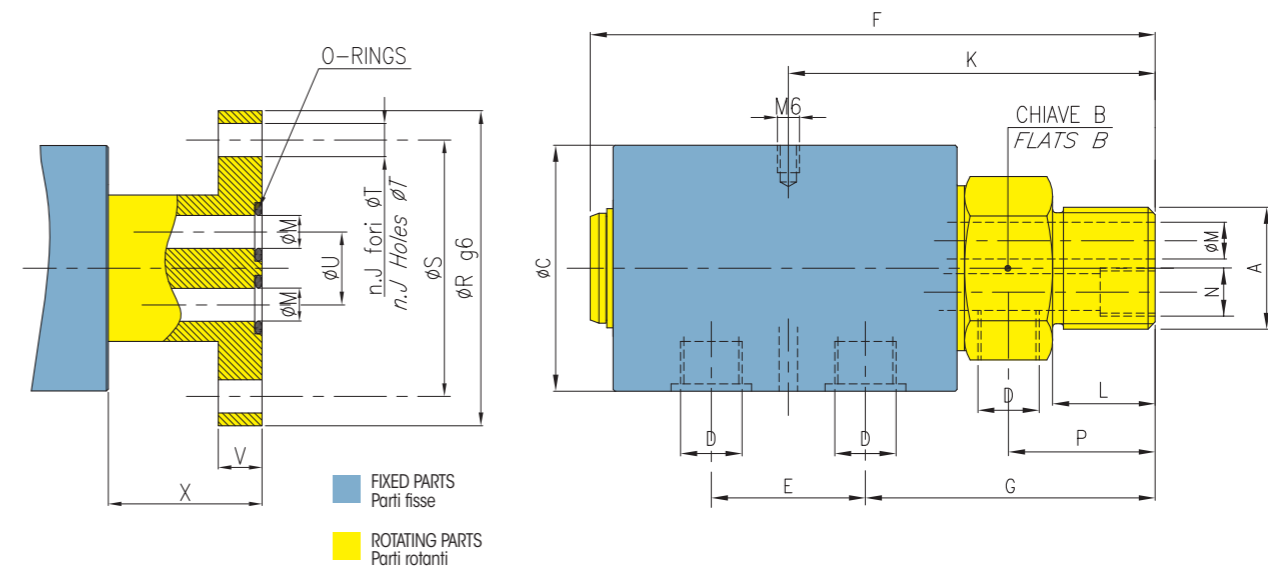

CODE codice	A	B	C	D	E	F	G	J	K	L
HDD025-GY6GS	3/4" BSP	41	67 2,637	1/4" BSP	42 1,653	154 6,062	79 3,110	/	92 3,622	24 0,944
HD0025-GY6LS	FLANGED frangiato	/	67 2,637	1/4" BSP	42 1,653	154 6,062	79 3,110	4	92 3,622	/
HDD037-GY6GS	1" BSP	55	67 2,637	3/8" BSP	42 1,653	154 6,062	79 3,110	/	92 3,622	28 1,102
HD0037-GY6LS	FLANGED frangiato	/	67 2,637	3/8" BSP	42 1,653	154 6,062	79 3,110	4	92 3,622	/
HDD050-GY6GS	1 1/4" BSP	60	79 3,110	1/2" BSP	53 2,086	182 7,165	91 3,582	/	118 4,645	29 1,141
HD0050-GY6LS	FLANGED frangiato	/	79 3,110	1/2" BSP	53 2,086	182 7,165	91 3,582	4	118 4,645	/

CODE codice	M	N	P	R	S	T	G	U	V
HD0025-GY6GS	8 0,314	1/8" BSP	35 1,377	/	/	/	/	/	/
HD0025-GY6LS	8 0,314	/	/	86 3,385	70 2,755	9 0,354	20 0,787	12 0,472	42 1,653
HD0037-GY6GS	10 0,393	1/4" BSP	40 1,574	/	/	/	/	/	/
HD0037-GY6LS	10 0,393	/	/	86 3,385	70 2,755	9 0,354	20 0,787	12 0,472	42 1,653
HD0050-GY6GS	13 0,511	3/8" BSP	44 1,732	/	/	/	/	/	/
HD0050-GY6LS	13 0,511	/	/	108 4,251	88 3,464	11 0,43	20 0,787	16 0,629	56 2,204

### Main features

- 1) Self supporting by two bearings
- 2) Vent hole
- 3) Shaft in steel chemical nickel plated
- 4) Aluminium housing
- 5) Size from 1/4" to 1/2" GAS

### Caratteristiche principali

- 1) Autosupportato da cuscinetti a sfera
- 2) Foro di sfato
- 3) Rotore in acciaio indurito e rivestito al niprolo
- 4) Corpo in alluminio anodizzato
- 5) Grandezze da 1/4" a 1/2" GAS

IH

## ROTATING UNION MULTIDIRECTIONAL // FROM 2 TO 9 DIRECTION Giunti rotanti multivie // da 2 a 9 vie

The Girol's IH series are multi ways rotating unions. They are designed to meet customers needs in different fields as steel, food, packaging and glass industries. In order to project this kind of rotating unions, we need to know the following parameters: number of ways, size of the ways, rotary speed, pressure, temperature and fluid of passage. The picture on the right shows a 17 ways rotating union produced for ArcelorMittal in Ukraina. We are already supplier in OEM and steel plants worldwide.

The Girol's IH series are multi ways rotating unions. They are designed to meet customers needs in different fields as steel, food, packaging and glass industries. In order to project this kind of rotating unions, we need to know the following parameters: number of ways, size of the ways, rotary speed, pressure, temperature and fluid of passage. The picture on the right shows a 17 ways rotating union produced for ArcelorMittal in Ukraina. We are already supplier in OEM and steel plants worldwide.

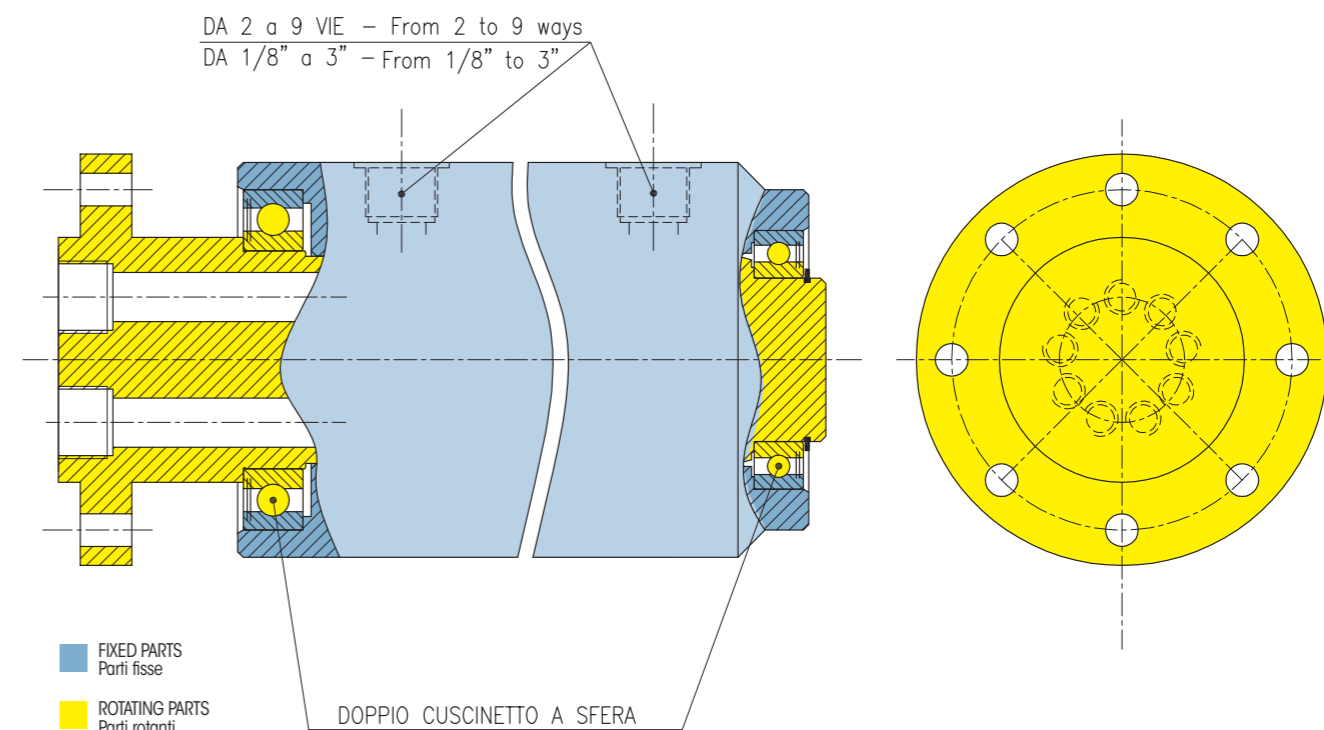
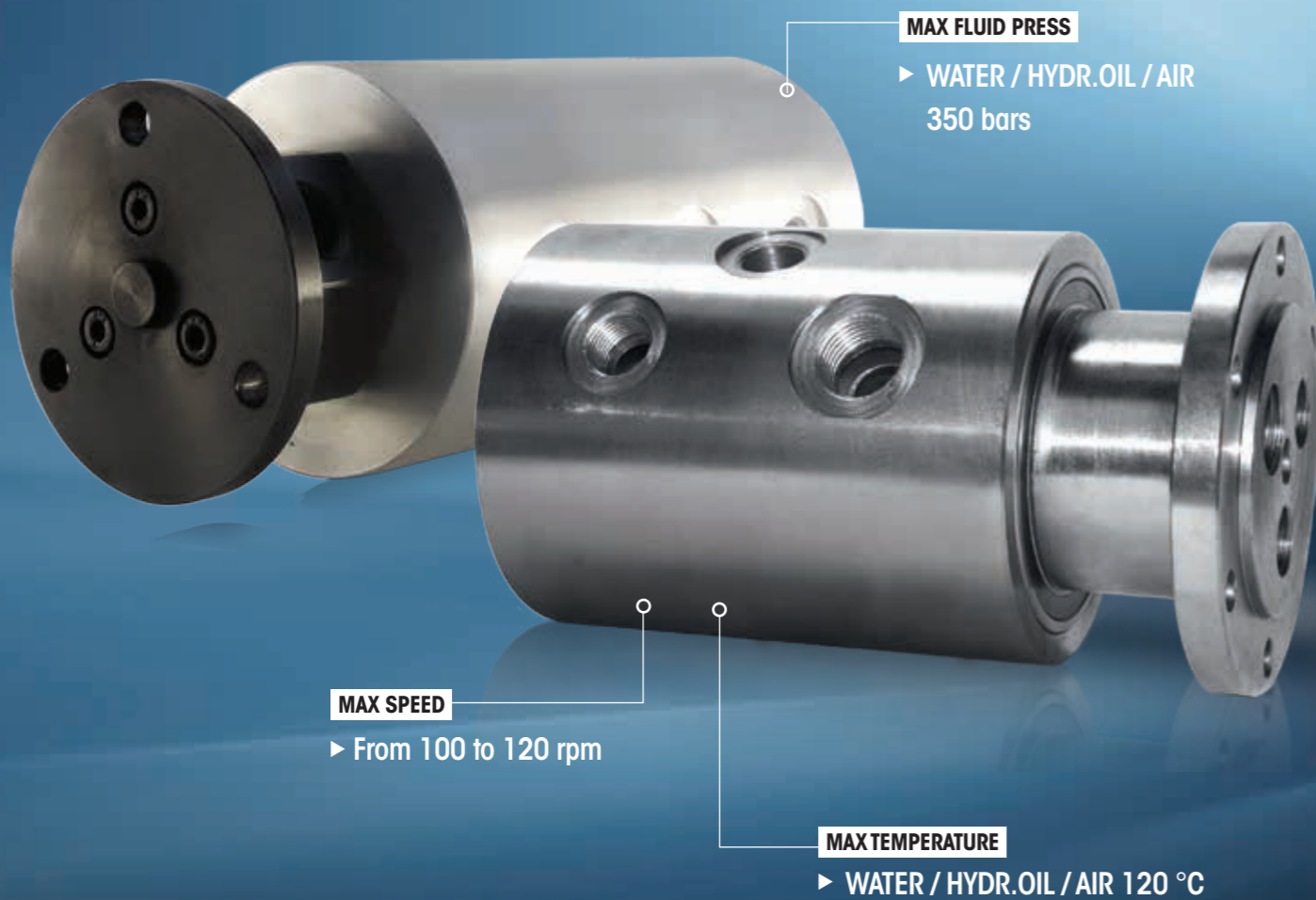

### Main features

- 1) Design on customer request
- 2) Self supporting by two bearings
- 3) Material on customer request
- 4) Number of ways from 2 to 9
- 5) Dimension of ways from 1/8" a 3" gas
- 6) Adaptable with electrical joint
- 7) Acciaio inox

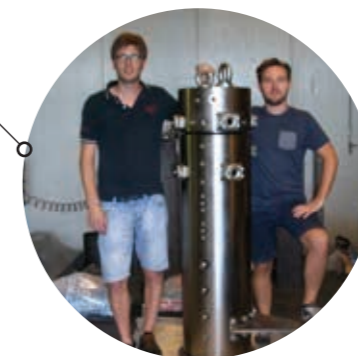

### Caratteristiche principali

- 1) Progettazione su misura in base alle esigenze
- 2) Autosupportazione mediante due cuscinetti a sfera
- 3) Materiali in base a qualsiasi richiesta
- 4) Numero passaggi da 2 a 9 vie
- 5) Grandezze passaggi da 1/8" a 3" gas
- 6) Adattabilità con collettori elettrici

# Y

## SWIVEL JOINT Snodi girevoli

I giunti girevoli della serie Y vengono in genere montati tra un tubo flessibile mobile e una parte rigida di una macchina per compensare torsioni e rotazioni occasionali: il movimento del perno sul proprio asse impedisce il danneggiamento del tubo. Sono utilizzati in tutti i settori produttivi ove vi siano mezzi, attrezzature o impianti dotati

di tubi flessibili in movimento. Sono disponibili anche in acciaio inossidabile AISI 316 dalla caratteristica colorazione nera-opaca di un particolare trattamento termico a cui sono sottoposti. Questo trattamento è fondamentale e viene eseguito per evitare il pericolo di grippaggio, molto alto, tra perno e corpo durante la rotazione e anche per aumentare la durata del giunto stesso. Si deve infine ricordare che i giunti in acciaio inossidabili hanno pressioni di utilizzo di 1/3 inferiori a quelle dei giunti standard.

The swivel joints of the Y series are designed to be mounted between a hose assembly and a rigid component of a machine in order to allow and compensate occasional rotations: the movement of the stem on his own axis prevents hose damages. They are used in every productive sector where there are means, equipments or plant with moving flexible hoses. These swivel joints are also available in stainless steel AISI 316 : they are black-dull owing to a special nitrocarburizing. This basic treatment is done to avoid the danger of seizure, very high, between stem and body during rotation and also to increase the swivel joint's life. At last we must to remember that stainless steel joints have lower work pressures compared to the standard type.



## AXIAL VERSION Versione assiale

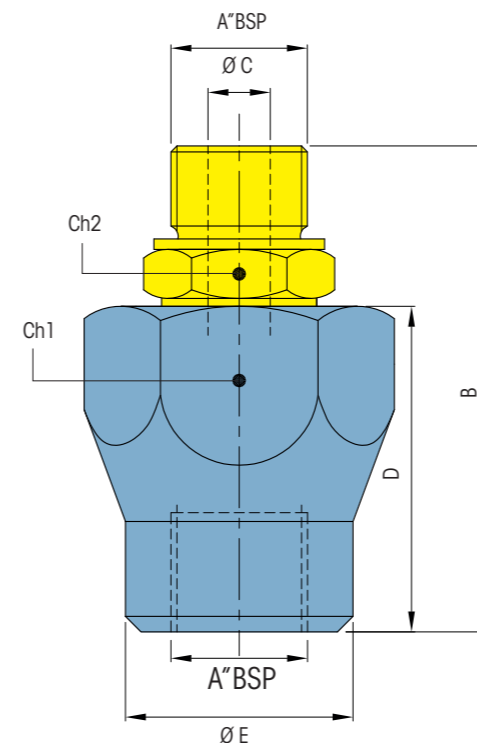

CODICE	A	B	C	D	E	CH.1	CH.2	MAX PRESS
Y-D025AGY6GS	1/4"	61	6	42	24	30	19	400 Bar
Y-D037AGY6GS	3/8"	66	8,5	44	25	34	24	400 Bar
Y-D050AGY6GS	1/2"	71	11,5	47	32	36	27	300 Bar
Y-D075AGY6GS	3/4"	80	15	50	49,5	45	34	300 Bar
Y-D100AGY6GS	1"	90	21	57	54,5	50	41	300 Bar
Y-D125AGY6GS	1 1/4"	101	28	63	60	55	50	300 Bar
Y-D150AGY6GS		110	35	70	69,5	65	55	300 Bar
Y-D200AGY6GS	2"	118	44	75	84,5	75	65	250 Bar

## RADIAL VERSION Versione radiale

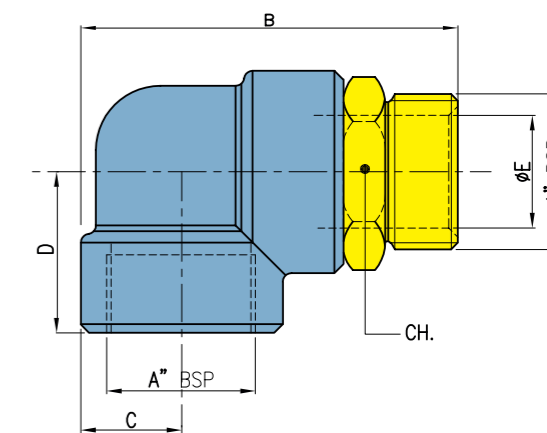
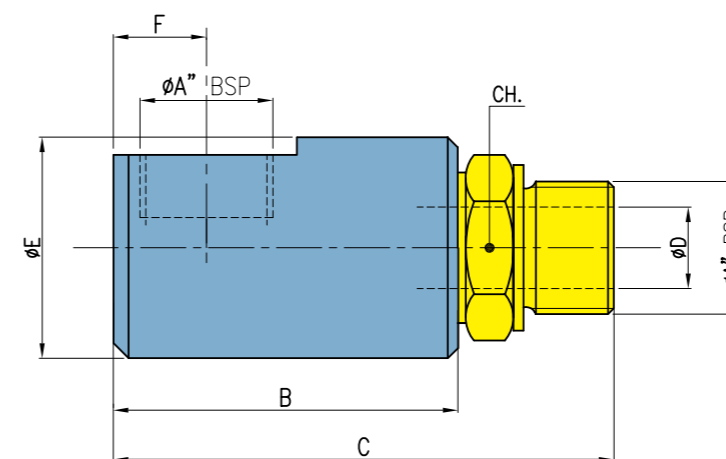

CODICE	A	B	C	D	E	F	CH	MAX PRESS
Y-D025-GY6GS	1/4"	50	69	6	33,5	11	19	400 Bar
Y-D037-GY6GS	3/8"	54	76	8,5	37,5	13	24	400 Bar
Y-D050-GY6GS	1/2"	63	87	11,5	39,5	14	27	300 Bar
Y-D075-GY6GS	3/4"	70	100	15	54,5	18	34	300 Bar
Y-D100-GY6GS	1"	80	113	21	60	24	41	300 Bar
Y-D125-GY6GS	1 1/4"	121	32	52	28	-	50	300 Bar
Y-D150-GY6GS	1 1/2"	143	37	62	34	-	55	300 Bar
Y-D200-GY6GS	2"	151	42	64	44	-	65	250 Bar

# AB

## ROTATING UNION // FOR HIGH PRESSURE AND SPEED

Giunto rotante // Per alte pressioni e velocità

The GIROL AB Series is used in applications with high pressure and at high rotation speed. A special bearing supports axial loads derivatives for high pressure. The union is made of nickel plated carbon steel.

I giunti GIROL delle serie AB, sono utilizzati in applicazioni ad alta pressione (300 BAR) unita ad alte velocità di rotazione. La robustezza dei cuscinetti consente di sostenere elevati carichi assiali dovuti dalla spinta delle alte pressioni. Il materiale costruttivo è acciaio al carbonio nichelato chimicamente.



**MAX FLUID PRESS**

► WATER - HYDR.OIL - AIR 300 bars

**MAX SPEED**

► From 500 to 3.000 rpm

**MAX TEMPERATURE**

► WATER - HYDR.OIL - AIR 120 °C

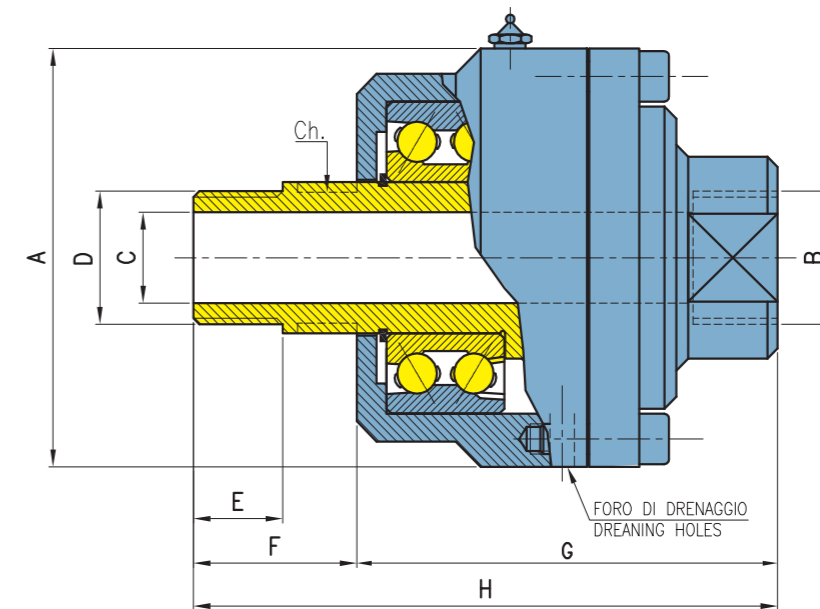

■ FIXED PARTS  
Parti fisse  
■ ROTATING PARTS  
Parti rotanti

For left thread, the third letter of code change replacing "D" with "S"  
Per filettature sinistre, la terza lettera del codice varia sostituendo "D" con "S"

CODE Codice	A	B	C	D	E	F	G	CH.1	CH.1	RPM g/min
ABD025-GS2KS	59 2,322	1/4" BSP	6 0,236	11 0,433	21 0,826	71 2,795	92 3,622	14	21	3.000
ABD037-GS2KS	66 2,898	3/8" BSP	10 0,393	12 0,472	22 0,866	79 3,110	101 3,976	17	26	2.500
ABD050-GS2KS	74 2,913	1/2" BSP	13 0,511	14 0,551	25 0,984	85 3,375	110 4,354	22	30	2.000
ABD075-GS2KS	84 3,307	3/4" BSP	18 0,708	14 0,551	25 0,984	85 3,375	123 4,842	26	36	1.500
ABD100-GS2KS	97 3,818	1" BSP	24 0,945	17 0,669	33 1,299	95 3,745	145 5,708	32	43	1.000
ABD125-GS2KS	112 4,409	1" /4BSP	32 1,259	21 0,826	41 1,614	112 4,409	165 6,496	46	54	1.000
ABD150-GS2KS	118 4,645	1" 1/2 BSP	38 1,496	25 0,984	48 1,809	118 4,645	165 6,496	46	60	800
ABD200-GS2KS	138 5,413	2" BSP	48 1,889	32 1,259	54 2,125	129 5,078	183 7,204	55	74	500

**Main features**

- 1) Double row contact ball bearings
- 2) Design for high pressure and high speed rotation
- 3) Size from 1/4" to 2" gas

**Caratteristiche principali**

- 1) Cuscinetti a due corone di sfere
- 2) Progettato per alte velocità e pressioni
- 3) Disponibili grandezze da 1/4" a 2" gas

# ON OFF

## ROTATING UNION // FOR DRY ROTATION Giunto rotante // Per rotazioni a secco

The GIROL ON-OFF Series has been designed for the passage of refrigerant fluids through the spindles of machine tools. This union can also operate without fluids passing (dry rotation) up to a high speed of 20,000 RPM. The fixed external part is made of anodized aluminum and the rotary part is made of nickel plated carbon steel.

I giunti GIROL della serie ON-OFF sono progettati per il passaggio di fluidi refrigeranti attraverso i mandrini delle macchine utensili. Questi giunti possono ruotare anche a secco (senza passaggio di fluido) insieme ad alte velocità di rotazione (fino a 20000 giri/min). Il materiale costruttivo della parte fissa esterna è alluminio anodizzato, mentre per la parte rotante interna è acciaio al carbonio nichelato.



**MAX FLUID PRESS**  
► COOLING FLUIDS 70 bars

**MAX SPEED**  
► From 10.000 to 20.000 rpm

**MAX TEMPERATURE**  
► COOLING FLUIDS 120 °C

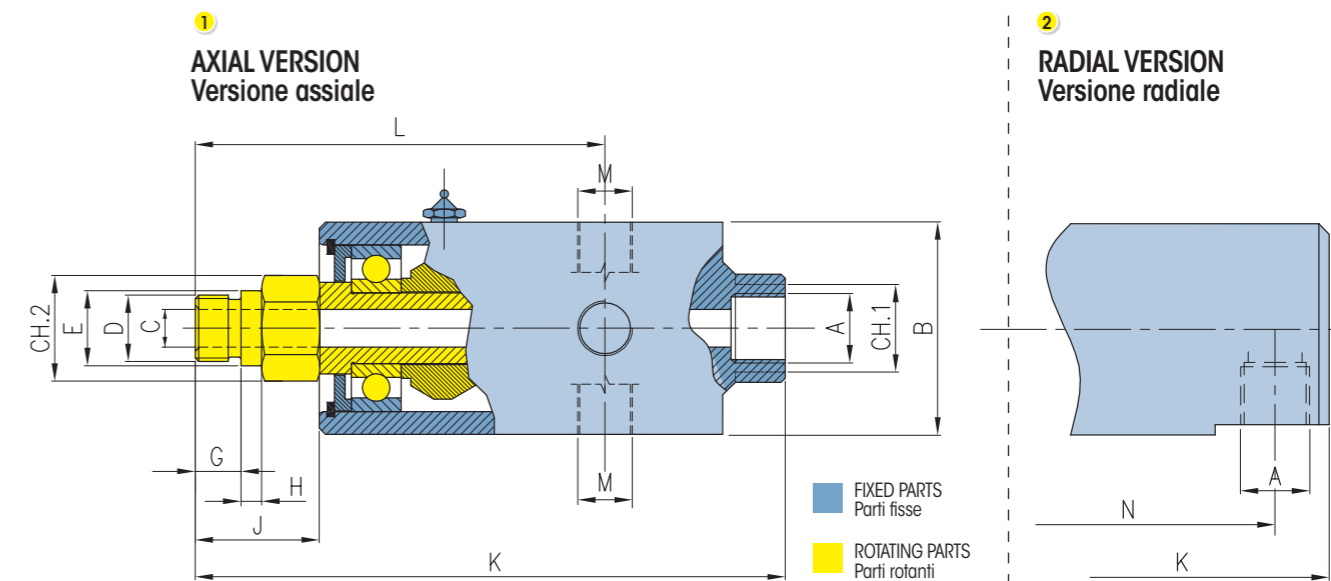

**1**

AXIAL VERSION Vers. Assiale	A	B	C	D	E (g6)	G	H	J	K	L	M	Ch.1	Ch.2
<b>ON-OFF0250L1*</b>	1/4" BSP	43 1,692	5 0,196	M10 X 1 LH	11 0,433	12 0,472	6 0,236	21 0,826	132 4,724	85 3,622	1/8" BSP	21	14
<b>ON-OFF0370L1*</b>	3/8" BSP	54 2,00	9 0,354	M16 X 1,5 LH	18 0,708	11 0,433	5 0,196	30 1,181	131 5,511	84 3,897	1/4" BSP	21	24

**2**

RADIAL VERSION Vers. Radiale	A	B	C	D	E (g6)	G	H	J	K	L	M	N	Ch
<b>ON-OFF0250L9</b>	1/4" BSP	43 1,692	5 0,196	M10 X 1 LH	11 0,433	12 0,472	6 0,236	21 0,826	121 5,263	92 3,622	1/8" BSP	122 4,802	17
<b>ON-OFF0370L9</b>	3/8" BSP	51 2,00	9 0,354	M16 X 1,5 LH	18 0,708	11 0,433	5 0,196	30 1,181	131 5,787	84 3,897	1/4" BSP	134 5,275	22

\*For high speed version (up to 20.000 rpm) replace "L" in the code with "H"  
Per versione ad alta velocità (fino a 20.000 rpm) sostituire nel codice la lettera "L" con la lettera "H"

### Main features

- 1) high speed ball bearings
- 2) Designed for rotating without fluids
- 3) Housing in alluminium anodizing
- 4) System for reserve the bearing
- 5) Silicon carbide seal

### Caratteristiche principali

- 1) Cuscinetti a sfera ad alta velocità
- 2) Progettato per rotazioni senza passaggio di fluido
- 3) Corpo in alluminio anodizzato
- 4) Labirinto di protezione cuscinetti
- 5) Tenute meccaniche in carburo di silicio

**K**

## UNIVERSAL ROTATING UNION WITH ROTARY SEALS

### Giunti rotanti universali con guarnizioni striscianti

The GIROL K Series is for air use up to 12 Bars and fluid use up to 70 Bars. This union has a shaft with cylindrical BSP threading (right or left-handed available). The seal is made of teflon and viton. The fixed external part is made of anodized aluminum and the rotary part is made of nickel plated carbon steel. On request, we can make unions in stainless steel AISI 316/304 for the food industry.

La fornitura standard dei giunti GIROL della serie K prevede il rotore con filettatura cilindrica GAS destra o sinistra. La tenuta viene effettuata con guarnizioni striscianti in teflon e viton. Il materiale costruttivo per la parte rotante è acciaio al carbonio trattato al nipro e la parte esterna in alluminio anodizzato. Su richiesta si eseguono versioni speciali in acciaio inox AISI 316/304 per usi alimentari.

#### MAX FLUID PRESS

- ▶ AIR 12 bars
- ▶ WATER - OIL - FLUIDS 70 bars



#### MAX SPEED

- ▶ STEAM - WATER - OIL - FLUIDS from 150 bar to 520 rpm

#### MAX TEMPERATURE

- ▶ AIR 80 °C
- ▶ WATER - OIL - FLUIDS 110 °C

## ROTATING UNION MONOFLOW

### Giunto Monovia

**KM**

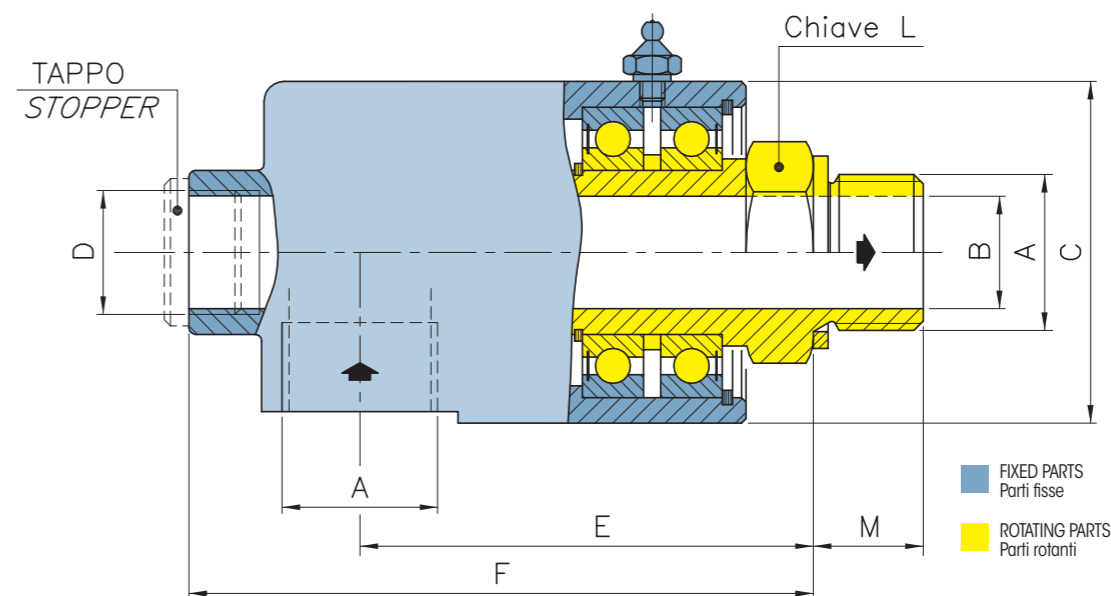

For left thread, the third letter of code change replacing "D" with "S"  
Per filettature sinistre, la terza lettera del codice varia sostituendo "D" con "S"

CODE Codice	A	B	C	D	E	F	L	M	RPM g/min
KMD025-GY6GX	1/4" BSP	6 0.236	36 1.417	/	60 2.362	74 2.914	17	14,5 0,571	520
KMD037-GY6GX	3/8" BSP	10 0.394	44 1.732	1/4" BSP	68 2.677	90 3.543	22	16 0.630	500
KMD050-GY6GX	1/2" BSP	13 0.512	52 2.047	3/8" BSP	76 2.992	101 3.976	27	18 0.709	450
KMD075-GY6GX	3/4" BSP	18 0.709	57 2.244	1/2" BSP	80 3.150	111 4.370	32	20 0.787	400
KMD100-GY6GX	1" BSP	24 0.945	73 2.874	3/4" BSP	97 3.819	134 5.276	41	23 0.906	350
KMD125-GY6GX	1" 1/4 BSP	32 1.260	87 3.425	1" BSP	113 4.449	158 6.220	50	29 1.142	300
KMD150-GY6GX	1" 1/2 BSP	38 1.496	94 3.701	1" 1/4" BSP	117 4.606	166 6.535	55	31 1.220	250
KMD200-GY6GX	2" BSP	48 1.890	108 4.252	1" 1/2 BSP	131 5.157	189 7.441	65	35 1.378	200

#### Main features

- 1) Ball bearings
- 2) Version for passage with food fluids
- 3) Size from 1/4" to 2" gas

#### Caratteristiche principali

- 1) Cuscinetti a sfera
- 2) Versioni per passaggio fluidi alimentari in acciaio inox
- 3) Grandezze standard da 1/4" a 2" gas

**KF**

**DUAL-FLOW UNIONS // FIXED SYPHON TUBE**

Giunti a due vie // Tubo sifone fisso

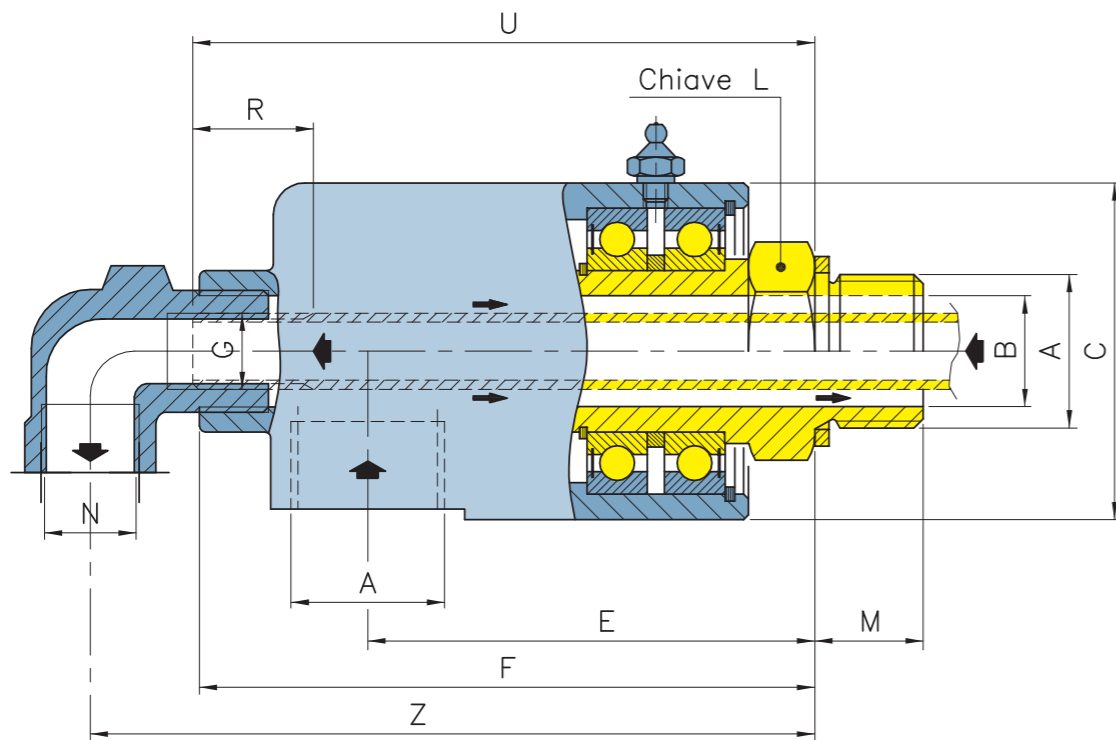

For left thread, the third letter of code change replacing "D" with "S"  
Per filettature sinistre, la terza lettera del codice varia sostituendo "D" con "S"

CODE Codice	G1 (optional)	G	N	R	U	Z
KFD039-GY6GX	/	M8X1	1/8"BSP	15 0,591	105 4,133	122 4,803
KFD052-GY6GX	/	1/8"BSP	1/4"BSP	15 0,591	100 3,937	134 5,276
KFD077-GY6GX	1/8"BSP	1/4"BSP	3/8"BSP	15 0,591	110 4,331	147 5,787
KFD102-GY6GX	1/4"BSP	3/8"BSP	1/2"BSP	15 0,591	130 5,118	174 6,850
KFD127-GY6GX	3/8"BSP	1/2"BSP	3/4"BSP	25 0,984	155 6,102	203 7,992
KFD152-GY6GX	1/2"BSP	3/4"BSP	1"BSP	25 0,984	165 6,495	222 8,740
KFD202-GY6GX	3/4"BSP	1"BSP	1 1/4"BSP	25 0,984	185 7,283	248 9,764

**Threaded pipe**

The elbow of KF series help to support the syphon and it will be screwed in the elbow.  
The thread must be concentric of rotating union's axis for avoid misalignment

**Tubo filettato**

La curva dei giunti serie KF fa da supporto al tubo sifone, il quale si avvita su di essa.  
Il filetto deve essere concentrico all'asse del giunto per evitare disassamenti rispetto all'asse del rullo

**KR**

**DUAL-FLOW UNIONS // FREELY ROTATING SYPHON TUBE**

Giunti a due vie // Tubo sifone rotante libero

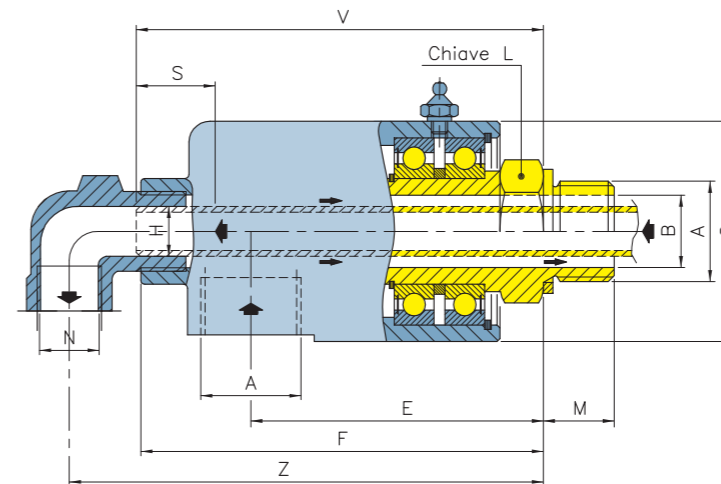

For left thread, the third letter of code change replacing "D" with "S"  
Per filettature sinistre, la terza lettera del codice varia sostituendo "D" con "S"

CODE Codice	H	S	V
KRD039-GY6GX	6 0,263	40 1,575	95 3,740
KRD052-GY6GX	9 0,354	40 1,575	105 4,133
KRD077-GY6GX	12 0,472	50 1,969	115 4,527
KRD102-GY6GX	16 0,630	50 1,969	165 5,496
KRD127-GY6GX	20 0,787	60 2,362	190 7,480
KRD152-GY6GX	25 0,984	60 2,362	200 7,874
KRD202-GY6GX	32 1,260	60 2,362	222 8,898

**Turning pipe**

Rotating syphon are fixed internally with the roll for rotating with it. The KR elbow help to support the pipe and restrict crosstalk passages. The pipe must be straight and concentric to the center line to avoid excess pipe and restrict crosstalk passages. The pipe must be straight and concentric to the center line to avoid center

**Tubo tornito**

I tubi rotanti sono fissati internamente al rullo per ruotare insieme con esso. La curva KR fa da supporto al sifone, il quale deve essere concentrico all'asse del giunto per evitare carichi eccessivi su di esso. Una rotazione superiore a 1.000 g/min è da evitare

**KT**

**DUAL-FLOW UNIONS // ROTATING SYPHON TUBE WITH SEAL**

Giunti a due vie // Tubo Sifone rotante con tenuta

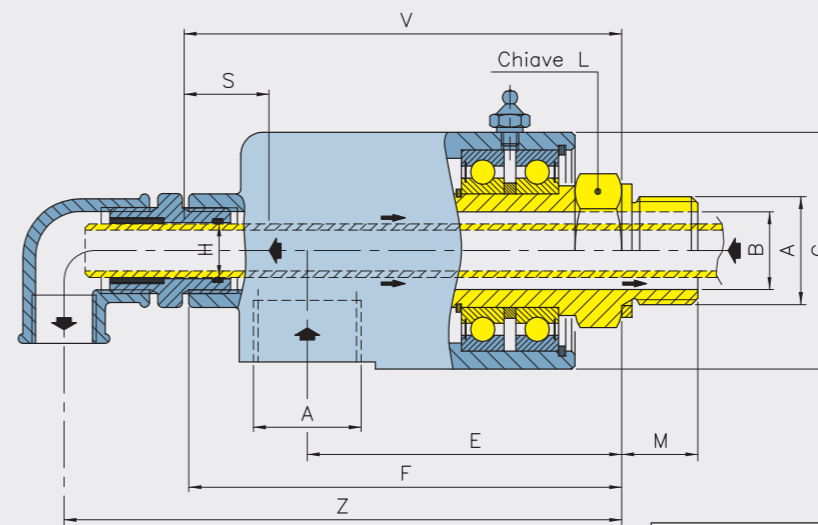

For KT series it's the same for KR series, but in the elbow there is one seal for double independent passage

Per la serie KT vale lo stesso discorso della serie KR, ma con la differenza che nella curva è presente una guarnizione che consente di avere due vie indipendenti.



**M**

## ROTARY UNION // FOR CONTINUOUS CASTING MACHINES

Giunto rotante // Per impianti di colata continua

The Girol M Series has been designed for mounting in the roll cylinder of continuous casting machines. To withstand dirty water, the seals are made of silicon carbide. The housing is traditionally made in brass. Special versions are available upon request.

I giunti GIROL della serie M sono progettati per essere incassati nei rulli delle linee di colata continua. Le tenute sono in carburo di silicio per resistere alle acque sporche delle acciaierie. Lo standard prevede il materiale costruttivo è l'ottone, sia per la parte fissa che per la parte rotante. Su richiesta si eseguono versioni speciali.



**MAX FLUID PRESS**

► WATER 10 bars

**MAX TEMPERATURE**

► WATER 120 °C

**MAX SPEED**

► WATER 100 rpm

**MS**

## ROTATING UNION MONOFLOW // EXTERNAL MOUNTING

Giunto monovia // Montaggio esterno

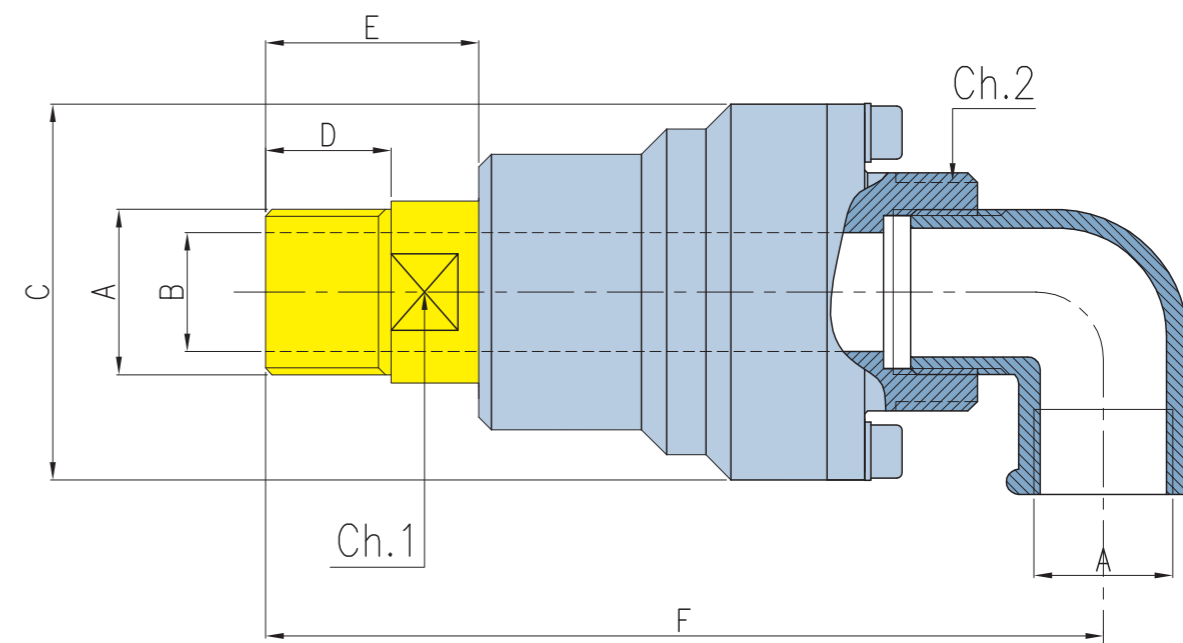

For left thread, the third letter of code change replacing "D" with "S"  
Per filettature sinistre, la terza lettera del codice varia sostituendo "D" con "S"

CODE Codice	A	B	C	D	E	F	Ch.1	Ch.2
<b>MSD050-GB2GS</b>	1/2" BSP	13 0.512	57 2.244	17 0.669	30 1.181	111 4.373	20	29
<b>MSD075-GB2GS</b>	3/4" BSP	18 0.709	64 2.519	20 0.787	34 1.338	136 5.354	25	40
<b>MSD100-GB2GS</b>	1" BSP	24 0.945	64 2.519	20 0.787	38 1.496	143 5.629	30	40
<b>MSD125-GB2GS</b>	1 1/4" BSP	32 1.260	87 3.425	24 0.944	45 1.771	167 6.574	38	50

### Main features

- 1) Version mono e double flow
- 2) Housing in brass
- 3) Special version on customer request
- 4) Silicon carbide seal

### Caratteristiche principali

- 1) Versione mono e doppio passaggio
- 2) Corpo e parte posteriore in ottone
- 3) Versioni speciali su misura
- 4) Tenute meccaniche in carburo di silicio

**ROTATING UNION MONOFLOW // IN SHAFT MOUNTING**

Giunto monovia // Montaggio incassato

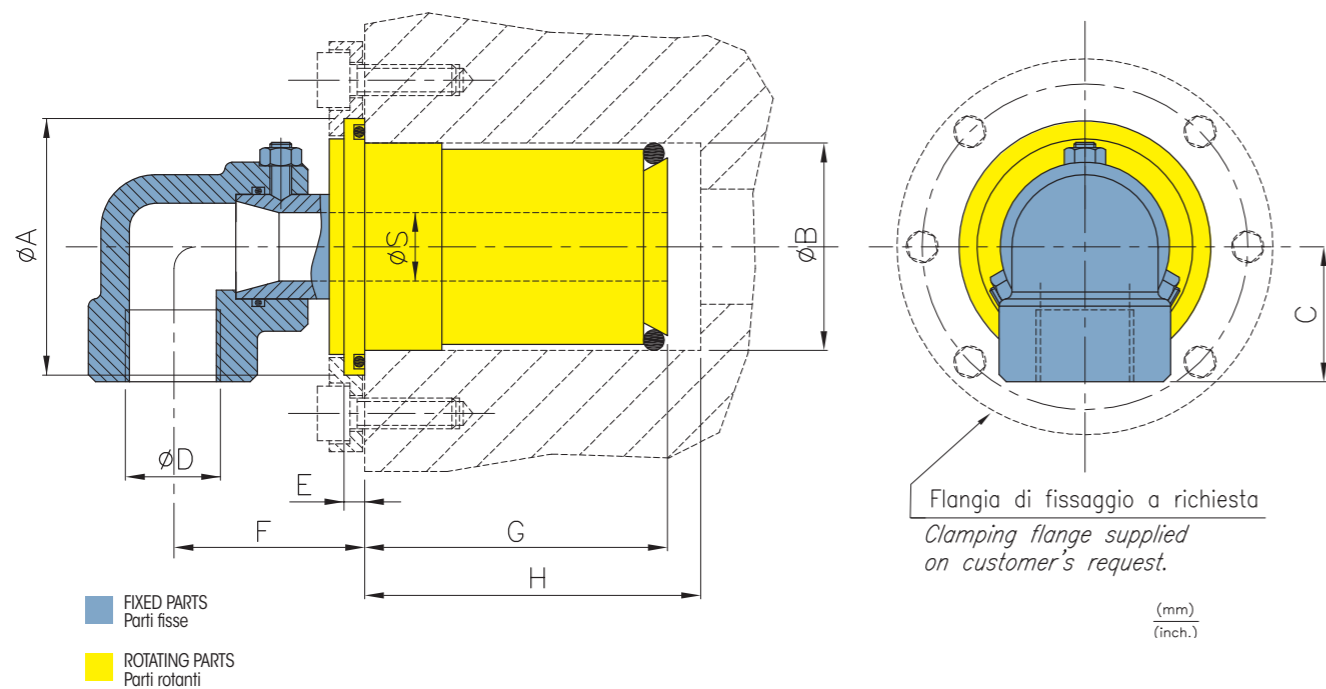

CODE Codice	A	B	C	D	E	F	G	H	S
<b>MM0050-LB2LX</b>	59 2,322	46,2 1,811	38 1,496	3/4" BSP	4 0,157	47 1,850	60 2,362	62 2,440	19 0,748
<b>MM0075-LB2LX</b>	73 2,874	58,8 2,322	38 1,476	3/4" BSP	5 0,196	47 1,850	78 3,070	82 3,228	25 0,984
<b>MM0100-LB2LX</b>	86 3,385	71 2,795	47 1,850	1" BSP	5 0,196	61 2,401	87 3,444	93,5 3,581	38 1,496

**Main features**

- 1) Version mono e double flow
- 2) In shaft mounting
- 3) Housing in brass
- 4) Special version on costumer request
- 5) Silicon carbide seal

**Caratteristiche principali**

- 1) Versione mono e doppio passaggio
- 2) Montaggio incassato
- 3) Corpo e parte posteriore in ottone
- 4) Versioni speciali su misura
- 5) Tenute meccaniche in carburo di silicio

**ROTATING UNION DOUBLE FLOW // IN SHAFT MOUNTING**

Giunto a due vie // Montaggio incassato

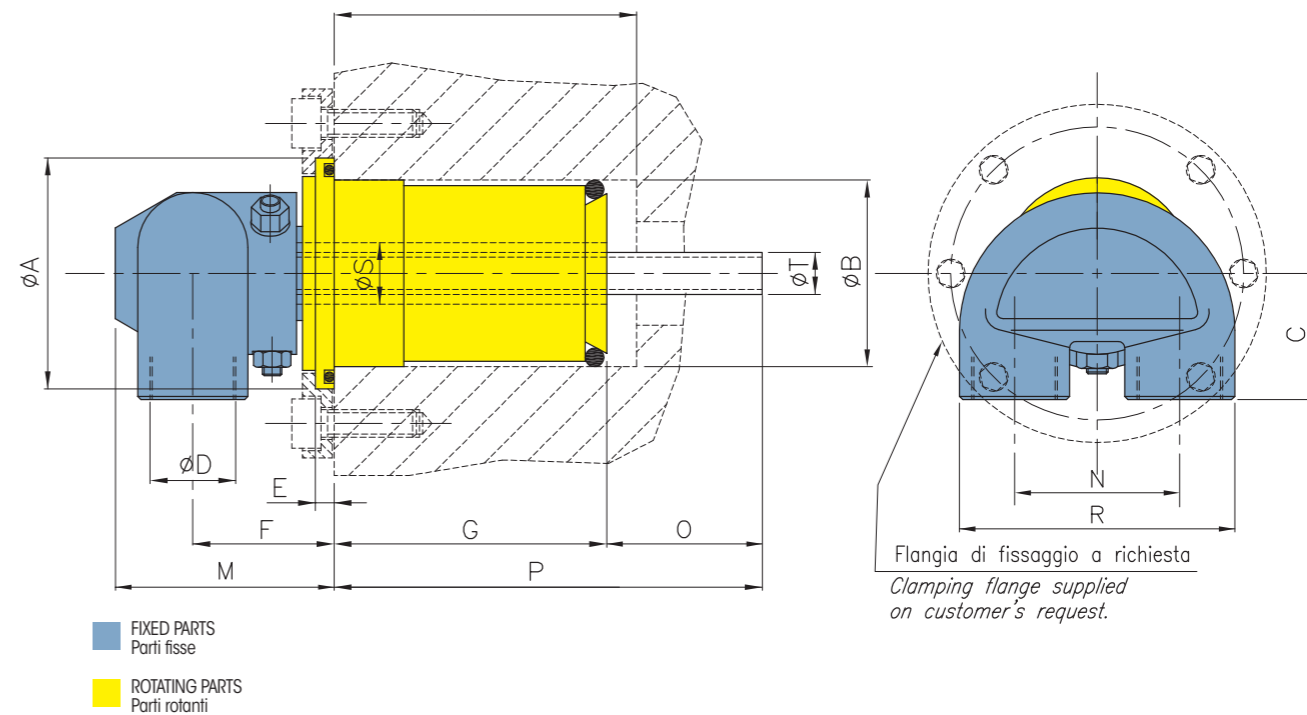

CODE Codice	A	B	C	D	E	F	G	H	M
<b>MD0050-LB2LX</b>	59 2,322	46,2 1,811	38 1,496	3/4" BSP	4 0,157	42 1,652	60 2,362	62 2,440	66 2,596
<b>MD0075-LB2LX</b>	73 2,874	58,8 2,322	38 1,476	3/4" BSP	5 0,196	42 1,652	78 3,070	82 3,228	82 3,228
<b>MD0100-LB2LX</b>	86 3,385	71 2,795	47 1,850	1" BSP	5 0,196	66 2,593	87 3,444	93,5 3,581	96 3,779

CODE Codice	N	O	P	R	S	T h9
<b>MD0050-LB2LX</b>	51 2,007	48 1,889	108 4,251	85 3,346	13 0,511	19 0,748
<b>MD0075-LB2LX</b>	51 2,007	61 2,401	139 5,472	85 3,346	19 0,748	25 0,984
<b>MD0100-LB2LX</b>	64 2,519	62,5 2,460	150 5,905	101 3,976	28,7 1,129	38 1,496

# Z

## ROTATING UNION // AXIAL OR IN SHAFT MOUNTING Giunto rotante // Per montaggio assiale o incassato

The standard supply provides the rotating nipple threaded cylindrical GAS right or left. On the request we supply other standard. Standard seal (graphite vs. stainless steel) in used for air and for water or hydraulic oil, seal of silicon carbide vs. silicon carbide in suggested. For liquid at pressure more than 60 bar (870 PSI) please contact our technician.

La fornitura standard comprende il rotore con filettatura cilindrica GAS destra o sinistra. Su richiesta forniamo rotori filettati secondo altri standard. La tenuta standard (grafite su acciaio Inox) si utilizza per aria e per acqua con filtraggio pari pari ad almeno 20 micron. Per liquidi con pressioni superiori a 60 bar si consiglia di consultare un nostro tecnico.

### MAX FLUID PRESS

- ▶ AIR 12 bars
- ▶ WATER - OILS-FLUIDS 70 bars

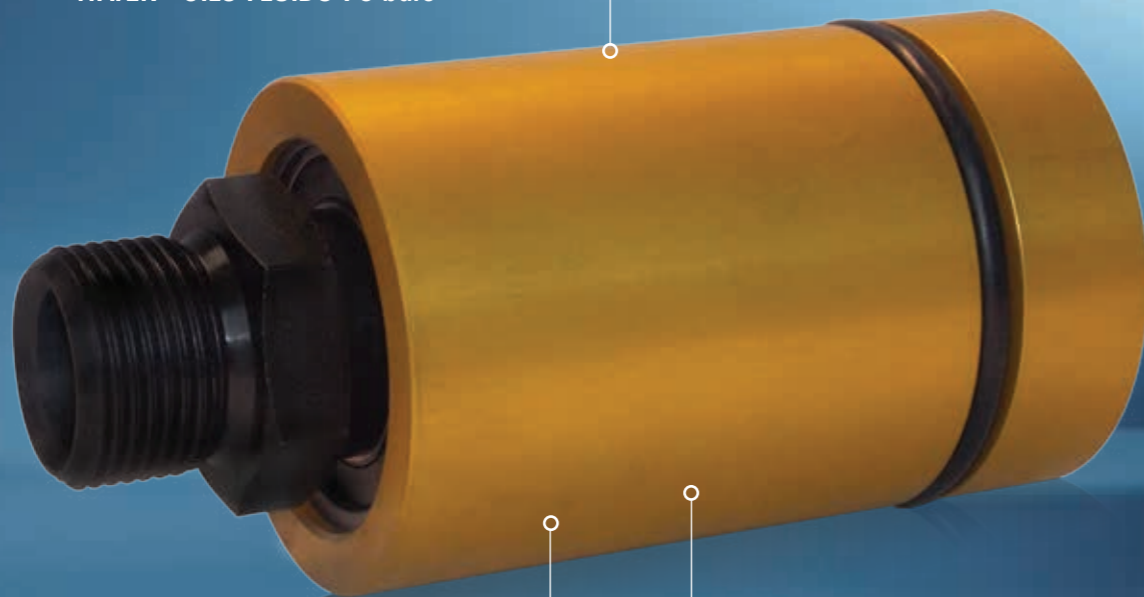

### MAX SPEED

- ▶ AIR - WATER - OILS - FLUIDS from 2.000 to 3.500 rpm

### MAX TEMPERATURE

- ▶ AIR 80 °C
- ▶ WATER-OILS-FLUIDS 110 °C

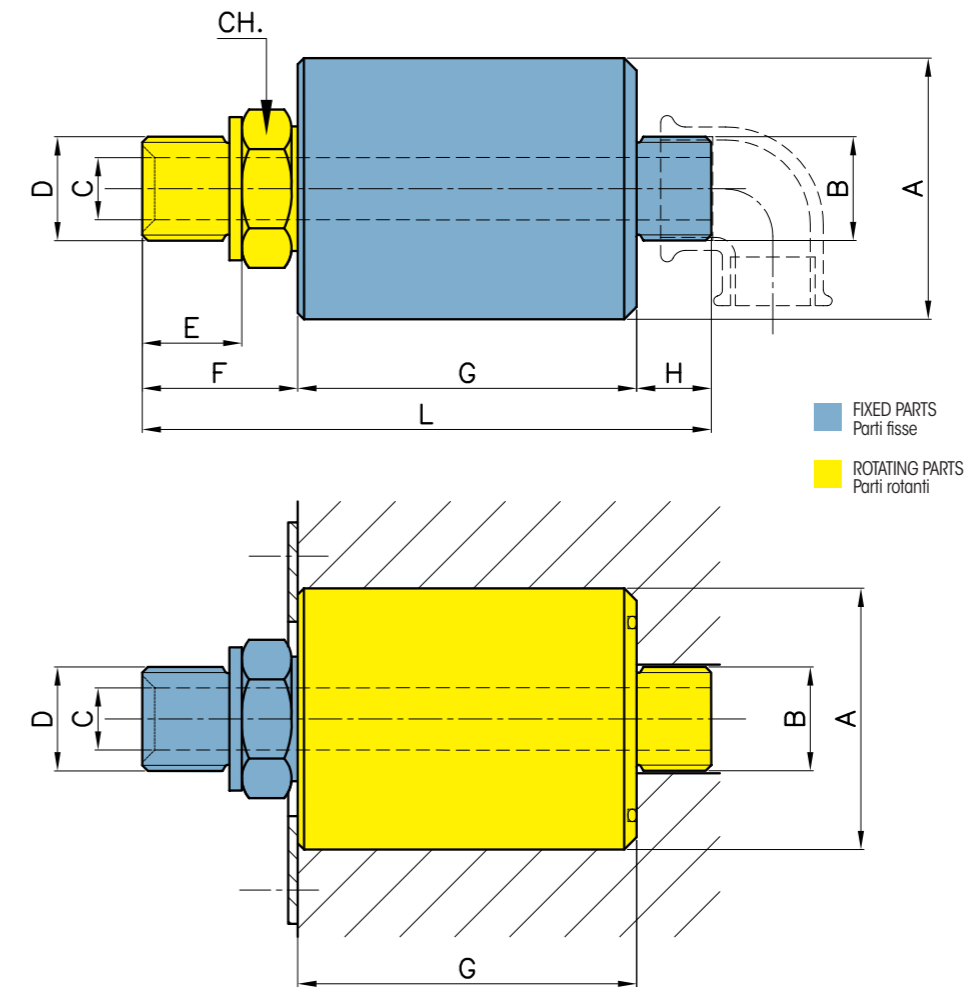

For left thread, the third letter of code change replacing "D" with "S"  
Per filettature sinistre, la terza lettera del codice varia sostituendo "D" con "S"

GRAPHITE-INOX Grafite-Inox	SILICON-SILICON Silicio-Silicio	A (h8)	B	C	D	E	F	G	H	RPM g/min	CH.
ZMD037-000D3	ZMD037-000D2	42 1,653	3/8" BSP	10 0,394	3/8" BSP	14 0,511	25 0,984	54,5 2,145	16 0,630	3.500	22
ZMD050-000D3	ZMD050-000D2	55 2,165	1/2" BSP	13 0,512	1/2" BSP	16 0,629	28 1,102	60,5 2,381	18 0,709	3.000	27
ZMD075-000D3	ZMD075-000D2	63 2,480	3/4" BSP	18 0,709	3/4" BSP	18 0,708	31 1,220	71,5 2,814	20 0,787	2.500	32
ZMD100-000D3	ZMD100-000D2	80 3,150	1" BSP	24 0,945	1" BSP	21 0,826	38 1,496	78,5 3,090	23 0,906	2.000	41

### Main features

- 1) ball bearing
- 2) Special version on request
- 3) Nichel plated steel
- 4) Possibility of axial mounting, with elbow or in shaft
- 5) Size from 3/8" to 1" gas

### Caratteristiche principali

- 1) Cuscinetti a sfera
- 2) Versioni speciali su richiesta
- 3) Acciaio nichelato chimicamente
- 4) Possibilità di montaggio assiale, con curva o incassato
- 5) Disponibili grandezze da 3/8" a 1" gas

## ROTATING SWIVEL LUBRICATION // VERY LOW SPEED

Snodo girevole per lubrificazione // Velocità molto basse

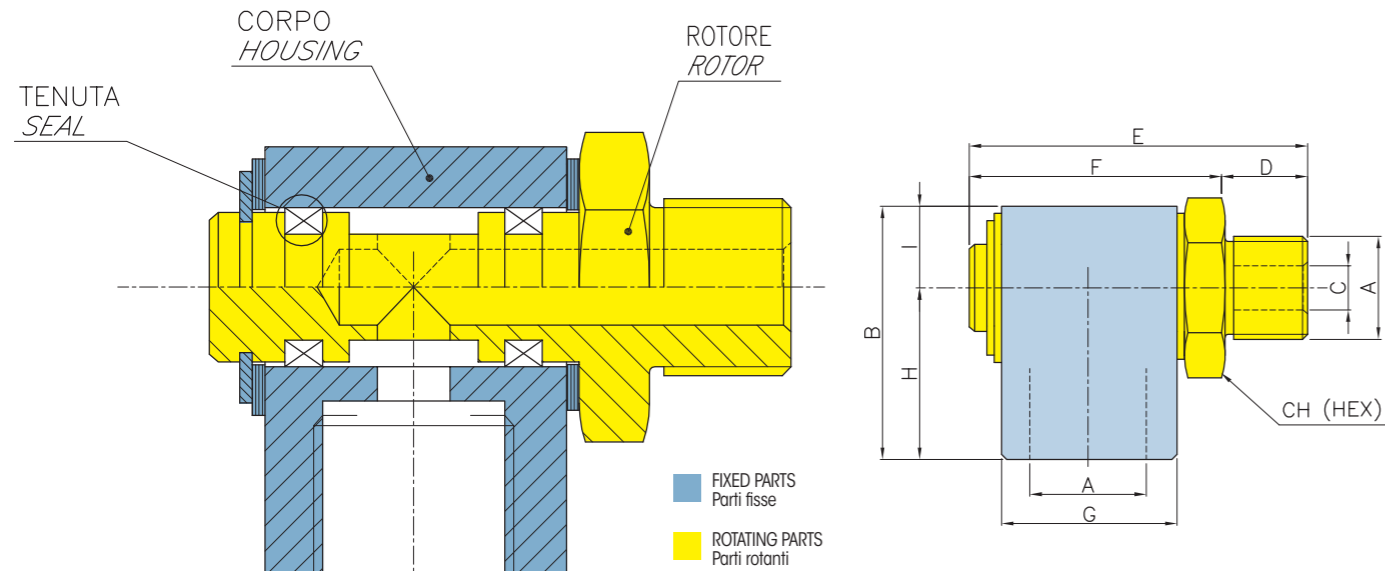

## SIMPLE ELBOW // FOR FIXED SYPHONS

Snodo semplice // Per sifoni fissi

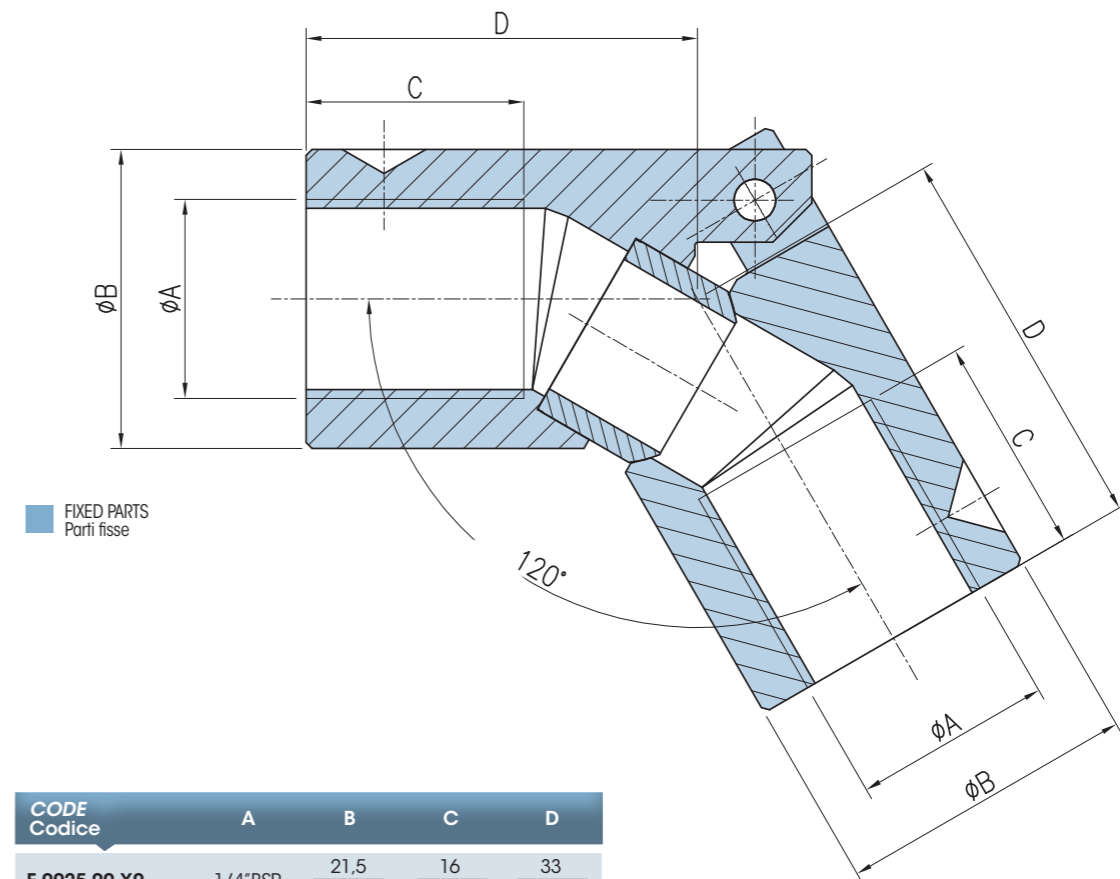

MAX OIL PRESS	pressione max olio	12 bar
MAX AIR PRESS	pressione max aria	10 bar
MAX TEMPERATURE	temperatura max	60 °C

### Main features

- 1) Sizes from 1/8" to 1"
- 2) Niployed steel rotor
- 3) BSP/NPT or metric thread
- 4) Brass housing

### Caratteristiche principali

- 1) Grandezze da 1/8" a 1"
- 2) Rotore in acciaio nichelato
- 3) Filettature GAS/BSP o metriche
- 4) Corpo in ottone

For left thread, the third letter of code change replacing "D" with "S"  
Per filettature sinistre, la terza lettera del codice varia sostituendo "D" con "S"

CODE Codice	A	B	C	D	E	F	G	H	I	CH.
RRD012-GB6GS	1/8" BSP	29 1,141	3 0,128	7,5 0,295	33 1,300	25,5 1,003	15 0,590	21 0,826	8 0,314	14
RRD025-GB6GS	1/4" BSP	31 1,220	5 0,196	12 0,472	43 1,692	31 1,220	20 0,747	21 0,826	10 0,393	19
RRD037-GB6GS	3/8" BSP	40 1,574	7 0,275	13 0,511	54 2,125	41 1,614	28 1,102	27 1,063	13 0,511	24
RRD050-GB6GS	1/2" BSP	46 1,811	11 0,433	16 0,629	60 2,362	44 1,732	30 1,181	31 1,220	15 0,590	30
RRD075-GB6GS	3/4" BSP	58 2,283	18 0,708	20 0,787	72 2,834	52 2,047	35 1,377	39,5 1,555	18,5 0,728	32
RRD100-GB6GS	1" BSP	68 2,677	23 0,905	23 0,905	86 3,385	63 2,480	42 1,653	46 1,811	22 0,866	38
RRD081-GB6GS	M8X1	29 1,141	3 0,128	7,5 0,295	33 1,300	25,5 1,003	15 0,590	21 0,826	8 0,314	14
RRD101-GB6GS	M10X1	29 1,141	3 0,128	7,5 0,295	33 1,300	25,5 1,003	15 0,590	21 0,826	8 0,314	14

CODE Codice	A	B	C	D
E-0025-00-X0	1/4" BSP	21,5 0,846	16 0,629	33 1,299
E-0037-00-X0	3/8" BSP	28 1,102	21 0,826	40 1,578
E-0050-00-X0	1/2" BSP	35 1,377	26 1,023	49 1,929
E-0075-00-X0	3/4" BSP	40 1,574	31 1,220	58 2,283
E-0100-00-X0	1" BSP	50 1,968	36 1,417	65 2,559
E-0125-00-X0	1 1/4" BSP	60 2,362	46 1,811	78 3,070
E-0150-00-X0	1 1/2" BSP	65 2,559	51 2,007	87 3,425
E-0200-00-X0	2" BSP	80 3,149	51 2,007	93 3,661
E-0250-00-X0	2 1/2" BSP	100 3,937	60 2,362	170 6,692
E-0300-00-X0	3" BSP	120 4,724	108 4,251	182 7,165

### Main features

- 1) Special version on request
- 2) Stainless steel AISI 420 with brass bush
- 3) Size from 1/4" to 3" GAS

### Caratteristiche principali

- 1) Versioni speciali su richiesta
- 2) Acciaio Inox AISI con boccia in bronzo
- 3) Disponibili grandezze da 1/4" a 3" GAS



## INSTALLATION

Installazione

### HOW TO INSTALL // COME INSTALLARE

1

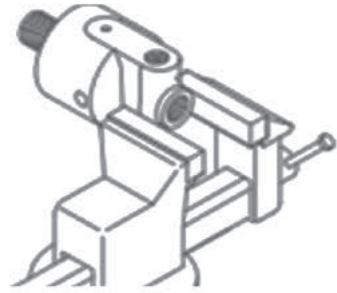

2

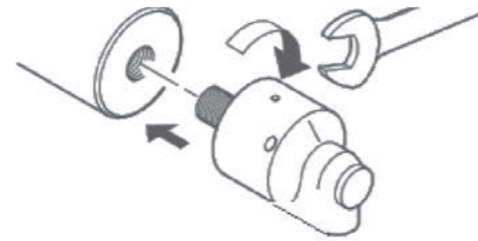

3

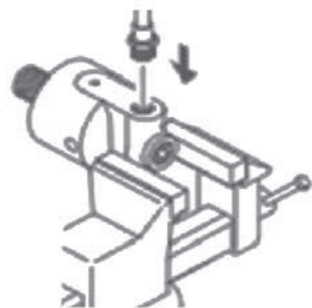

4



### HOW TO **NOT** INSTALL // COME **NON** INSTALLARE

1

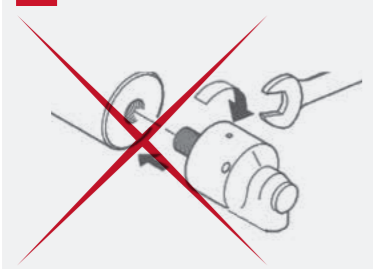

2



3

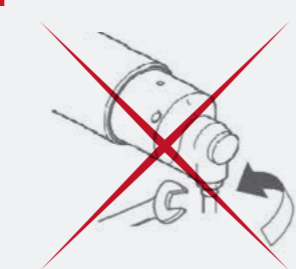

**PIPES MUST BE FLEXIBLE!**  
**I TUBI DEVONO ESSERE FLESSIBILI**



+34 943 377 740

info@diprax.es

www.diprax.es

Polígono Industrial Belartza,  
Gurutzegi Kalea 17 Pab  
D4 – D5, 20018 San Sebastián

