

HCDH

hydraulique *hydraulic*
caractéristiques techniques *performances*



• une crémaillère *one rack*

modèle <i>model</i>	rotation			Couple <i>torque</i> [Nm]		charge maxi radiale <i>radial load max</i> [N]	charge maxi axiale <i>axial load max</i> [N]	cylindrée volumétrique <i>displacement</i> [cm ³ /°]	poids <i>weight</i> [kg]		
	100 bar <i>1430 PSI</i>	210 bar <i>3000 PSI</i>	90°	180°	360°						
HCDH 105	69	145	90°	180°	360°	4000	400	0,14	2,8	2,9	3,5
HCDH 110	205	430	90°	180°	360°	8000	800	0,4	7	7,4	8,8
HCDH 116	425	890	90°	180°	360°	10000	1000	0,83	12,4	12,6	15,5
HCDH 117	620	1300	90°	180°	360°	19000	1900	1,25	15	16	19
HCDH 124	950	2000	90°	180°	360°	25000	2500	1,87	21,6	23	30
HCDH 125	1340	2800	90°	180°	360°	32000	3200	2,7	37,5	38,5	45

• deux crémaillères *two racks*

HCDH 205	138	290	4000	400	0,28	4,2	4,4	5,5
HCDH 210	410	860	8000	800	0,8	10,5	11,3	14,5
HCDH 216	840	1760	10000	1000	1,66	18	18,6	25
HCDH 217	1240	2600	19000	1900	2,5	22,3	23,7	30,2
HCDH 224	1900	4000	25000	2500	3,74	31,6	34,4	48,4
HCDH 225	2670	5600	32000	3200	5,4	52,5	54,5	75

encombrements (en mm) *dimensions* (in mm)

HCDH	A			B	C	D	E	F	G	H	I	J	K	L	M	N	O	P	Q	R
	90°	180°	360°																	
105/205	100,5	113	163	68	82	68	65f7	2,5	54	54	M8	14	17x15x1	37,5	25	25	1/8	40	40	7,5
110/210	146	164	240	98	120	92	94f7	3	76	92	M10	18	30x16x1.667	50	30	40	3/8	56	56	10
116/216	171	194,5	300	158	160	78	116f7	16	100	140	M12	20	40x14x2,5	58	38	50	3/8	78	56	22
117/217	225	260	392	140	200	78	132f7	11	100	176	M14	25	50x18x2,5	53	36	65	3/8	78	56	22
124/224	251	286	430	178	180	110	146f7	14	130	130	M16	16	55x20x2,5	72	40	75	3/8	80	80	22
125/225	340	400	600	240	240	116	200f7	20	140	200	M16	16	75x28x2,5	84	54	100	3/8	80	80	22



HPSD

hydraulique *hydraulic*
caractéristiques techniques *performances*



• simple palette *single vane*

modèle <i>model</i>	rotation	couple <i>torque</i> [Nm]			charge maxi radiale <i>radial load max</i> [N]	charge maxi axiale <i>axial load max</i> [N]	cylindrée volumétrique <i>displacement</i> [cm ³ /°]	fuite interne maxi à 100 bar <i>by-pass leakage at 1430 PSI</i> [cm ³ /mn]	poids <i>weight</i> [kg]
		70 bar <i>1000 PSI</i>	100 bar <i>1430 PSI</i>	140 bar <i>2000 PSI</i>					
HPSD 102	270°	20	30		1 000	10	0,059	20	0,6
HPSD 103	270°	44	63		2 000	10	0,128	45	1,3
HPSD 106	270°	85	122		2 000	10	0,25	50	1,7
HPSD 110	280°	210	300	420	6 000	50	0,62	70	6
HPSD 119	280°	420	600	840	6 000	50	1,24	100	8,5
HPSD 132	280°	1160	1650	2300	30 000	50	3,3	150	14
HPSD 184	280°	4200	6000	8400	70 000	100	12,4	200	100

• double palette *double vane*

HPSD 202	90°	42	60		1 400	10	0,118	25	0,7
HPSD 203	90°	90	130		36 000	10	0,255	50	1,4
HPSD 206	90°	176	252		30 000	10	0,5	60	1,9
HPSD 210	100°	450	640	900	13 000	50	1,24	80	7,5
HPSD 219	100°	880	1250	1750	13 000	50	2,47	130	9,5
HPSD 232	100°	2380	3400	4800	56 000	50	6,6	180	15
HPSD 284	100°	8400	12000	16800	100 000	100	24,9	230	105

encombremments (en mm) *dimensions* (in mm)

HPSD	A	B	C	D	E	F	G	H	I	J	K	L	M	N	O	P	Q	R	S	T	U	V	W	X	Y
102/202	36 g 6	92	59	23	3	M5	45	15	1	34			5	22,5	22	M5	14 g 6	68		1/8	28°	8	8		
103/203	50 g 6	107	80	32	3	M6	63	22	1	37			6	26	28	M8	20 g 6	74		1/8	22° 30°	8	10		
106/206	50 g 6	107	80	32	3	M6	63	22	1	49,5			6	26	28	M8	20 g 6	99		1/8	22° 30°	8	12		
110/210	94 f 7	193	118	58	11	M8	110	40	3	55	30	40	10	31,5	55	M10	36 g 6	110	50	1/4	14	15	16	18	
119/219	94 f 7	244	118	69	11	M8	110	40	3	80,5	40	80,5	10	32,5	55	M10	36 g 6	161	50	1/4	14	15	16	18	
132/232	100 f 7	252	196	104	13	M10	190	55	6	69	48	57	14	46	85	M16	50 g 6	129	80	3/8	28	20	30	30	24
184/284	170 f 7	446	300	168	20	M20	280	90	8	101	80	85	14	46	140	M24	85 g 6	250	120	3/4	40	40	45	45	48

vérins rotatifs

rotary actuators

rotary actuators

vérins rotatifs

vérins rotatifs

rotary actuators

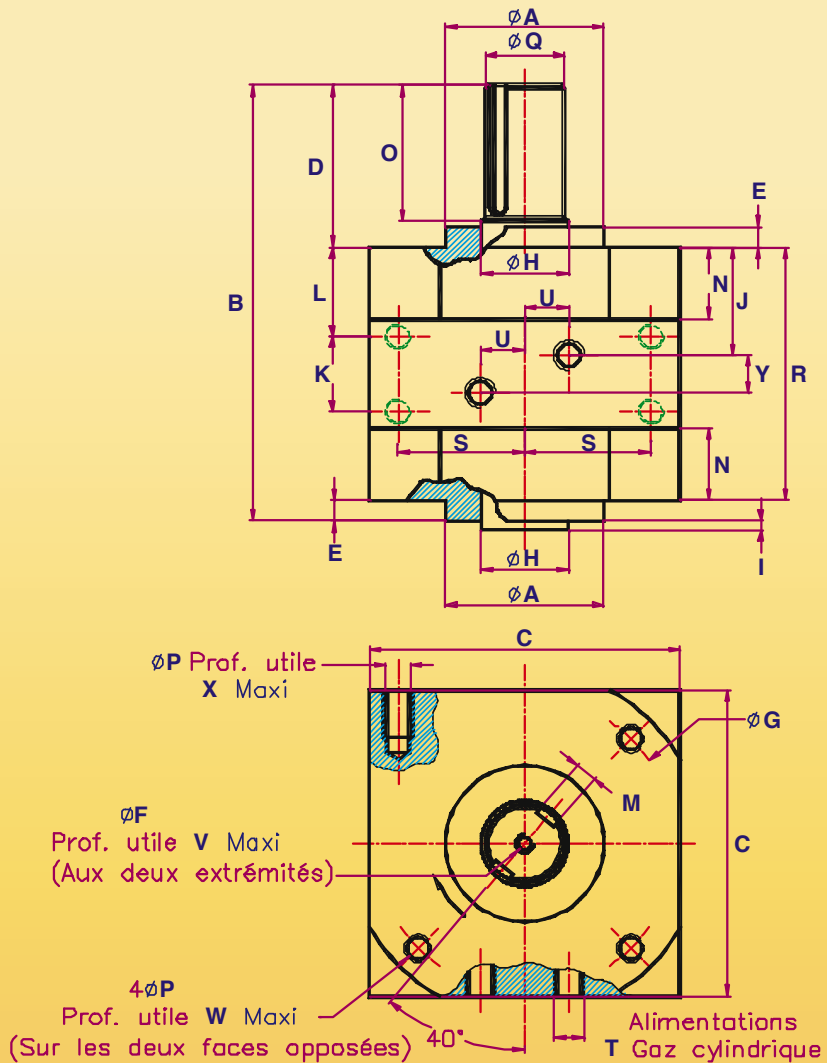
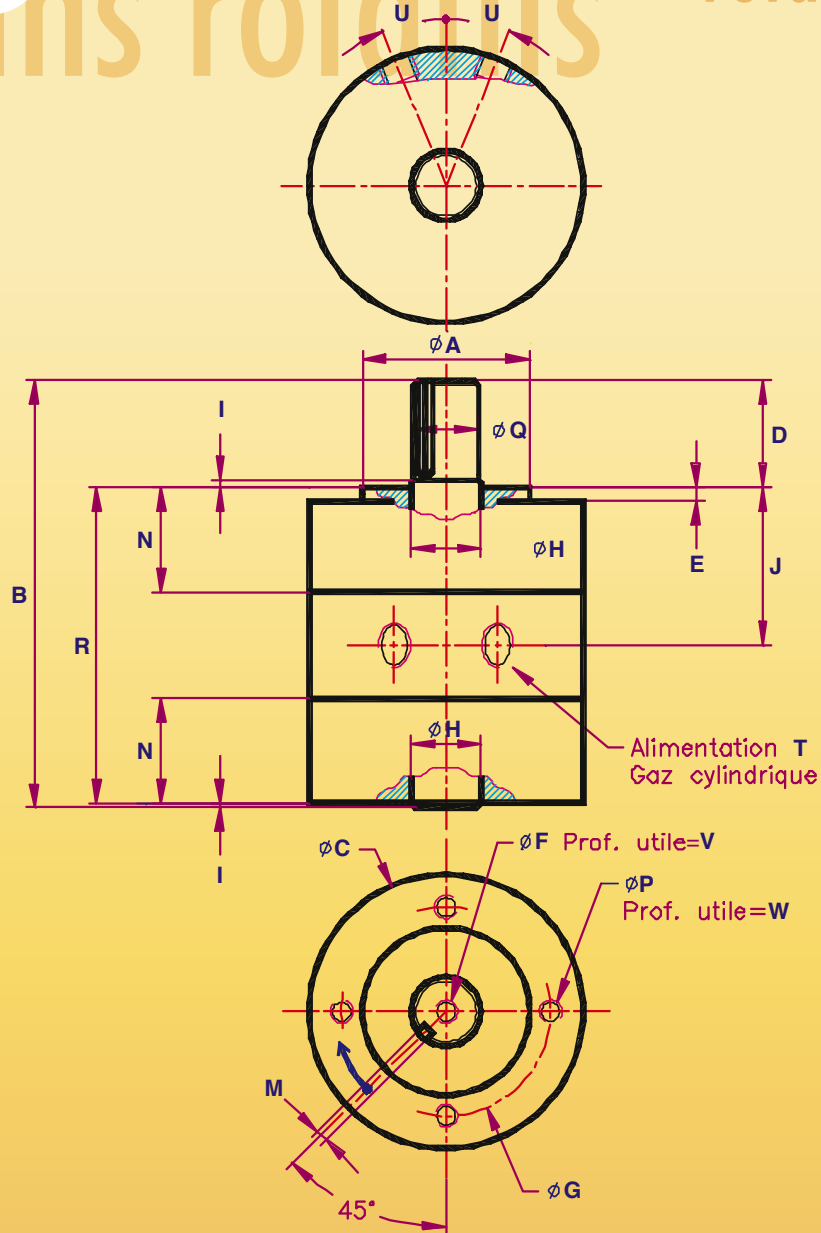



MP

hydraulique *hydraulic*

caractéristiques techniques *performances*



• simple palette *single vane*

modèle <i>model</i>	rotation	couple <i>torque</i> [Nm]		cylindrée <i>volumetric displacement</i> [cm ³ / °]	pression de <i>décollage</i> <i>break max</i>	fuite interne maxi à 100bar <i>by-pass leakage</i> <i>max at 1430 PSI</i> [cm ³ /mn]	poids <i>weight</i> [kg]
		70 bar <i>(1000 PSI)</i>	100 bar <i>(1430 PSI)</i>				
MP-11	280°	13	19	0.05	3.4	66	0.34
MP-22	280°	77	110	0.22	3.1	66	1.36
MP-32	280°	180	270	0.54	2.8	82	8.6
MP-34	280°	360	514	1.1	2.8	82	12
MP-63	280°	1050	1500	3.1	2.8	98	55
MP-84	280°	2497	3567	7.5	2.8	131	92
MP-105	280°	4972	7103	15	2.8	164	158
MP-116	280°	8113	11590	24	2.8	197	250
MP-128	280°	11565	16521	34	2.8	229	379

• double palette *double vane*

modèle <i>model</i>	rotation	couple <i>torque</i> [Nm]		cylindrée <i>volumetric displacement</i> [cm ³ / °]	pression de <i>décollage</i> <i>break max</i>	fuite interne maxi 100 bar <i>by-pass leakage</i> <i>max at 1430 PSI</i> [cm ³ /mn]	poids <i>weight</i> [kg]
		70 bar <i>(1000 PSI)</i>	100 bar <i>(1430 PSI)</i>				
MPR-1x.4	100°	3.50	5	0.015	3.4	57	0.1
MPR-1x1	100°	9.60	13.7	0.04	3.4	57	0.14
MP-11	100°	36	51	0.09	3.4	82	0.38
MP-22	100°	168	240	0.42	3.1	82	1.45
MP-32	100°	382	546	1.1	2.8	98	9
MP-34	100°	763	1090	2.1	2.8	98	12
MP-63	100°	2215	3164	6	2.8	115	57
MP-84	100°	5277	7539	15	2.8	147	96
MP-105	100°	10543	15061	30	2.8	180	165
MP-116	100°	17187	24553	48	2.8	213	264
MP-128	100°	24490	34986	69	2.8	246	397

encombres (en mm) *dimensions (in mm)*

	MPR 1x.4	MPR 1x1	MP 11	MP 22	MP 32	MP 34	MP 63	MP 84	MP 105	MP 116	MP 128
B					165	216	276	327	378	454	507
C	16	16	25.4	36	52	52	88.6	114	114	127.5	140
E			13.7	22.9	28.5	28.5	44.5	63.5	69.8	82.6	101.6
F			12.7	19	31.6	31.6	50.6	63.3	76	88.7	101.4
GR					69.9	69.6	108	133.4	133.4		
H					7.6	7.6	12	12	12	12	2.3
J					82.5	133.4	139.7	152.4	177.8	241.3	285.8
L			3x1.6	4.8x2.4	8x4	8x4	12.7x6.4	15.9x7.9	19x19.5	25.4x12.7	25.4x12.7
M			15.2	25.4	25.4	28.5	44.5	63.5	69.8	95.3	101.6
N			12.7	19.01	31.7	31.7	50.8	63.5	76.2	88.9	101.6
P			3/8-24 SAE	1/2-20 SAE	7/8-14	7/8-14	1 1/16-12	1 5/16-12	1 5/8-12	1 7/8-12	1 7/8-12
Q	6.6	6.6	10.7	16.5	24	24	31.8	41.4	50.8	63.5	63.5
R					19	19	25.4	25.4	25.4	31.8	31.75

	MPR 1x.4	MPR 1x1	MP 11	MP 22	MP 32	MP 34	MP 63	MP 84	MP 105	MP 116	MP 128
S					108	108	203	267	317.5	362	406.4
T					53.98	53.98	101.6	133.4	158.8	181	203.2
U					53.9	53.9	101.6	133.4	158.8	180.8	203.2
V					41.4	41.4	76.2	108	127	152.4	171.5
X					108	108	203	267	317.5	362	406.4
Y	11.9	11.9	21.3	31.8	41.4	41.4	76.2	108	127	152.4	171.5
AA					3/8-16 0.56 DP		3/4-10 1.12 DP		1-8 1.75 DP		11/4-7 2 DP
BB	35	35	50.8 SQ	76.2 SQ	159	159	279	343	419	464	521
CC	13.8	13.8	21.3	31.8	66.8	66.8	120.7	152.4	184.2	206.2	231.6
EE					10	10	25.4	38	44.5	44.5	51
KK					14	14	24	24	30.5	36.6	40
LL			12.7	18.8	27.4	27.4	49.5	49.5	62	73.9	81
MM			5.6	7.1	10.4	10.4	19.8	19.8	26.2	26.2	33.5



HS

hydraulique *hydraulic*

caractéristiques techniques *performances*



- **simple palette***
single vane

modèle <i>model</i>	rotation	couple <i>torque</i> [Nm]			cylindrée <i>volumetric displacement</i> [cm ³ /°]	pression de <i>décolage break max</i> [bar]	fuite interne <i>maxi à 210 bar by-pass leakage max at 3000 PSI</i> [cm ³ /mn]	poids <i>weight</i> [kg]
		70 bar <i>1000 PSI</i>	140 bar <i>2000 PSI</i>	210 bar <i>3000 PSI</i>				
HS-1.5	280°	153	305	458	0.4	3.44	160	13
HS-2.5	280°	254	509	763	0.7	3.44	190	15
HS-4	280°	407	814	1220	1.1	3.44	230	19
HS-6	280°	646	1293	1939	1.8	3.44	250	26
HS-10	280°	972	1944	2915	2.7	3.44	300	30
HS-15	280°	1526	3051	4576	4.3	3.44	350	38

* modèle HS hydraulique double palette nous consulter *model HS double vane please contact DS dynatec*

encombremments (en mm) *dimensions (in mm)*

	HS-1.5	HS-2.5	HS-4	HS-6	HS-10	HS-15		HS-1.5	HS-2.5	HS-4	HS-6	HS-10	HS-15
A	155.5	175.8	206.3	184.2	209.6	253.2	Q	22.2	22.2	22.2	36.5	36.5	36.5
C	17.5	17.5	17.5	17.5	17.5	17.5	R	81.8	81.8	81.8	112.8	112.8	112.8
D	46	46	46	63.5	63.5	63.5	W	127	127	127	177.8	177.8	177.8
F	38.2	38.2	38.2	50.9	50.9	50.9	X	158.8	158.8	158.8	215.9	215.9	215.9
G	76.2	76.2	76.2	92	92	92	AA	1/2-13 (25.4)	1/2-13 (25.4)	1/2-13 (25.4)	1/2-13 (25.4)	1/2-13 (25.4)	1/2-13 (25.4)
H	6.4	6.4	6.4	6.4	6.4	6.4	BB				127	127	127
L	7.94x3.96	7.94x3.96	7.94x3.96	9.53x4.76	9.53x4.76	9.53x4.76	CC				5/8-11 (28.7)	5/8-11 (28.7)	5/8-11 (28.7)
M	35	57.2	88.9	76.2	114.3	177.8	DD				184.15	209.55	253.24
P	9/16-18	9/16-18	9/16-18	3/4-16	3/4-16	3/4-16	NN	(11.89) (31.75)	(11.89) (31.75)	(11.89) (31.75)	(15.06) (31.75)	(15.06) (31.75)	(15.06) (31.75)

vérins rotatifs

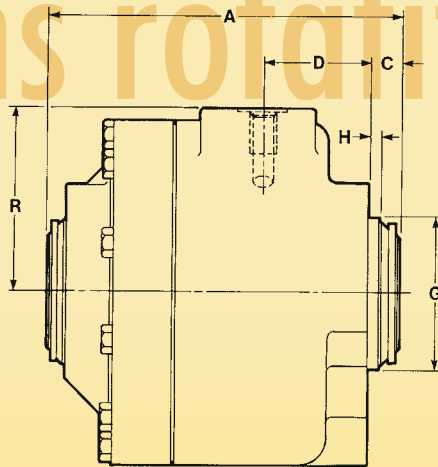

*KEY MUST BE CENTERED ON THE LONGITUDINAL CENTER OF THE ACTUATOR. KEYWAY IS FULL LENGTH OF SHAFT.

• simple palette *single vane*

rotary actuators

rotary actuators

rotary actuators

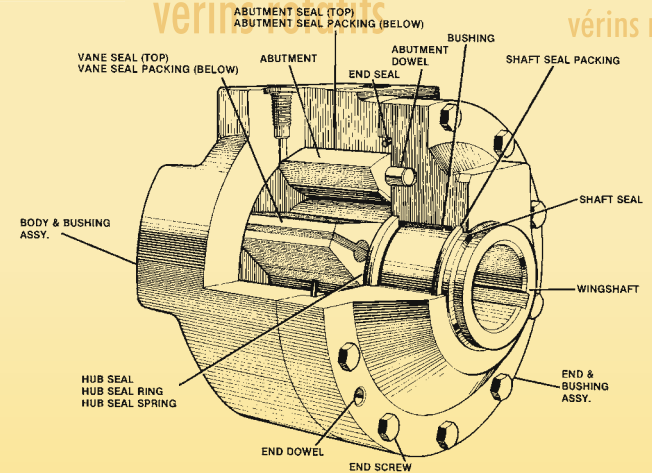

• double palette *double vane*

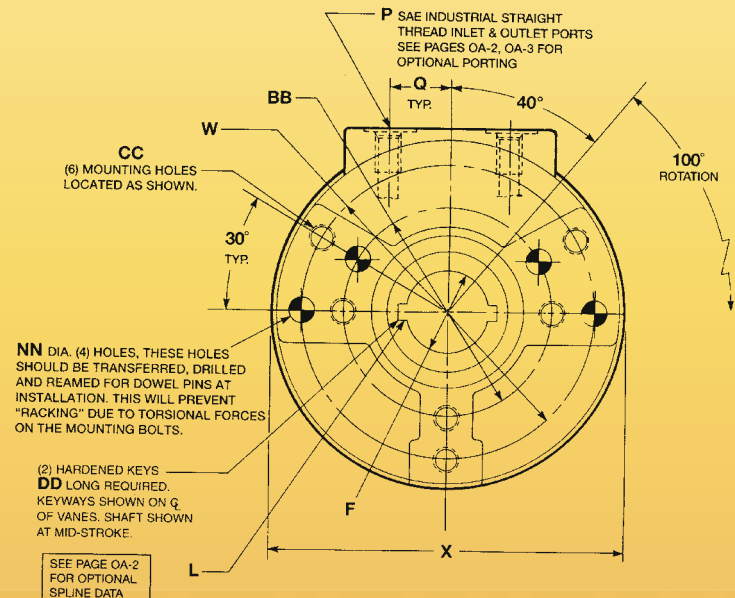
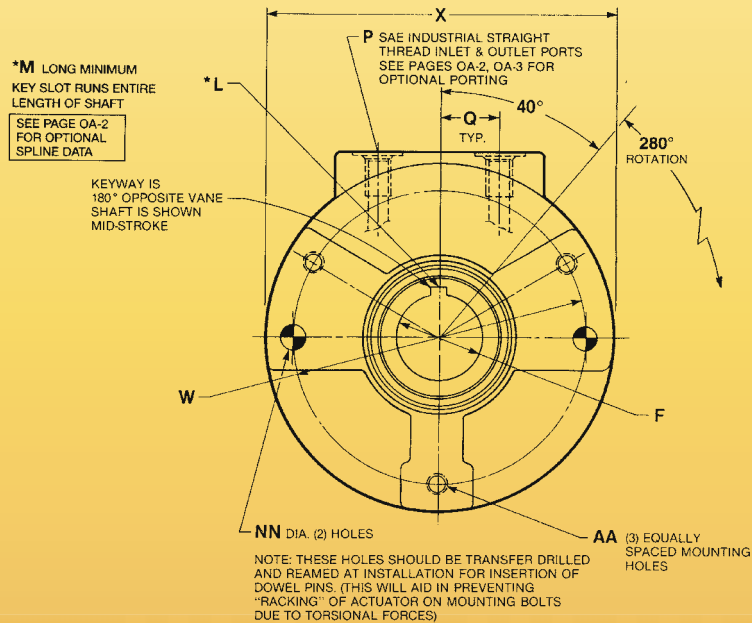

vérins rotatifs rotary actuators

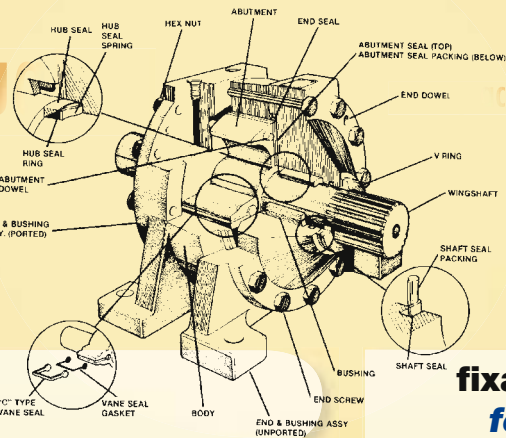

actuators
vérins rotatifs
SS rotary actuators

fixation latérale base mounting

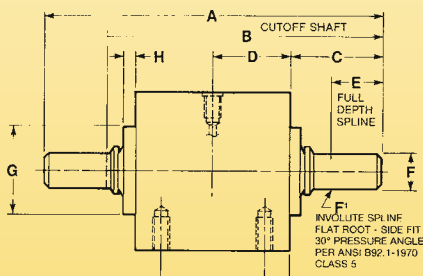

SEE PAGE OA-2 FOR OPTIONAL TAPPED SHAFT ENDS AND POTENTIOMETER MOUNTING HOLES

fixations frontales end mounting

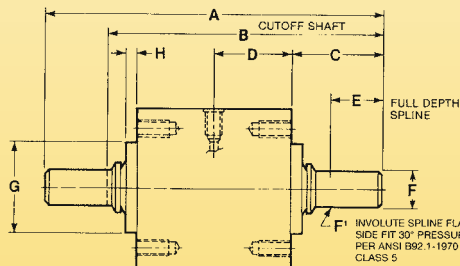

SEE PAGE OA-2 FOR OPTIONAL TAPPED SHAFT ENDS AND POTENTIOMETER MOUNTING HOLES

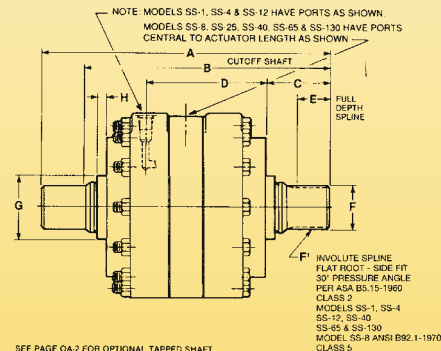

SEE PAGE OA-2 FOR OPTIONAL TAPPED SHAFT ENDS AND POTENTIOMETER MOUNTING HOLES

fixation par pieds foot mounting

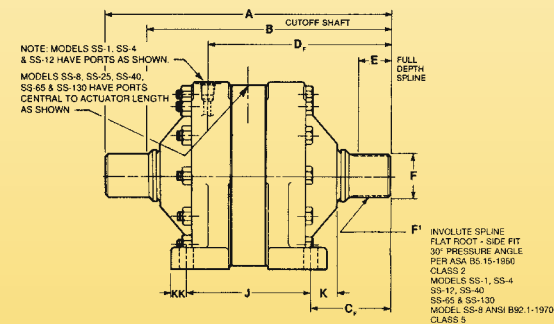

NOTE: MODELS SS-1, SS-4 & SS-12 HAVE PORTS AS SHOWN. MODELS SS-8, SS-25, SS-40, SS-65 & SS-130 HAVE PORTS CENTRAL TO ACTUATOR LENGTH AS SHOWN.

NOTE: MODELS SS-1, SS-4 & SS-12 HAVE PORTS AS SHOWN. MODELS SS-8, SS-25, SS-40, SS-65 & SS-130 HAVE PORTS CENTRAL TO ACTUATOR LENGTH AS SHOWN.

SS 2A & SS 5A

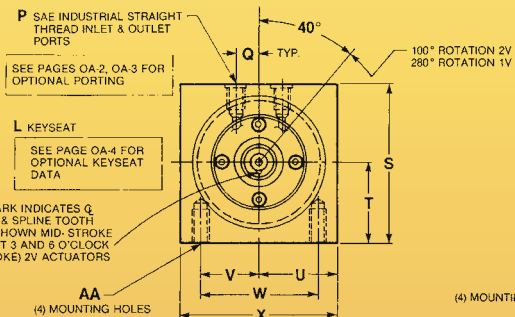

SEE PAGES OA-2, OA-3 FOR OPTIONAL PORTING

SEE PAGE OA-4 FOR OPTIONAL KEYSEAT DATA

INDEX MARK INDICATES Q OF VANE & SPLINE TOOTH 1V UNIT SHOWN MID-STROKE MARKS AT 3 AND 6 O'CLOCK (MIDSTROKE) 2V ACTUATORS

AA ((4) MOUNTING HOLES

SS 2A & SS 5A

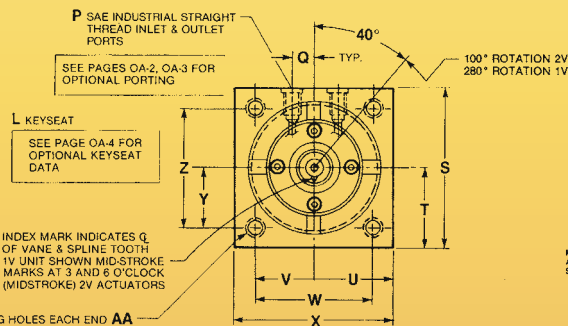

SEE PAGES OA-2, OA-3 FOR OPTIONAL PORTING

SEE PAGE OA-4 FOR OPTIONAL KEYSEAT DATA

INDEX MARK INDICATES Q OF VANE & SPLINE TOOTH 1V UNIT SHOWN MID-STROKE MARKS AT 3 AND 6 O'CLOCK (MIDSTROKE) 2V ACTUATORS

AA ((4) MOUNTING HOLES EACH END

SS 1 & SS 130

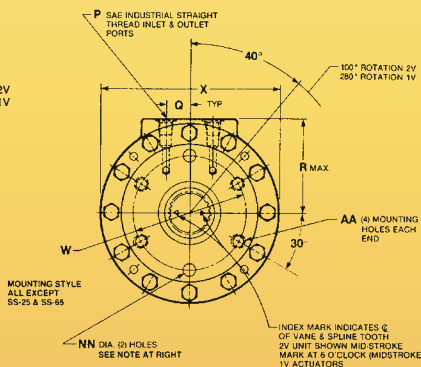

MOUNTING STYLE ALL EXCEPT SS-25 & SS-65

NN DIA (Ø) HOLES SEE NOTE AT RIGHT

INDEX MARK INDICATES Q OF VANE & SPLINE TOOTH 2V UNIT SHOWN MID-STROKE MARK AT 6 O'CLOCK (MIDSTROKE) 1V ACTUATORS

SS 1 & SS 130

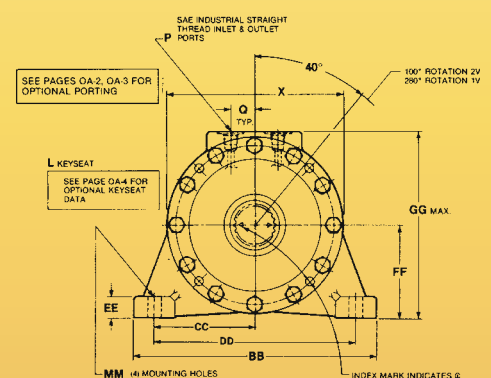

SEE PAGES OA-2, OA-3 FOR OPTIONAL PORTING

SEE PAGE OA-4 FOR OPTIONAL KEYSEAT DATA

SEE PAGE OA-3 FOR OPTIONAL TAPPED SHAFT ENDS AND POTENTIOMETER MOUNTING HOLES

INDEX MARK INDICATES Q OF VANE & SPLINE TOOTH 2V UNIT SHOWN MID-STROKE MARK AT 6 O'CLOCK (MIDSTROKE) 1V ACTUATORS

"REGU" régulateur hydraulique

neutralise les accélérations et les effets de rebond pendant la rotation

Le "REGU" de DS dynatec

- neutralise l'accélération d'un mouvement de rotation
- permet un réglage précis de la régulation
- neutralise les effets de rebond en fin de course
- freine la rotation en cas de rupture accidentelle de l'alimentation



applications

Le "REGU" peut être appliqué sur un angle de maximum 260° à une rotation, une oscillation, un retournement, un perçage, un meulage, une transmission ...

Il en résulte

- un mouvement régulier,
- aucune rebond en butée de fin de course,
- une vitesse de rotation constante,
- une possible récupération de jeu.

Les principaux secteurs d'application industrielle du "REGU" sont :

- l'automobile
- les lignes d'assemblage
- les lignes de transfert
- les verreries
- les minipulateurs

avantages

- la compacité
- la robustesse
- l'autonomie
- un réglage simple et durable
- la propreté
- l'adaptabilité

options

- différentes viscosités de remplissage
- deux sorties d'arbre
- indicateurs de position
- traitement anti-corrosion
- régulation mono-directionnelle

"REGU" en récupération de jeu de denture sur un moto réducteur

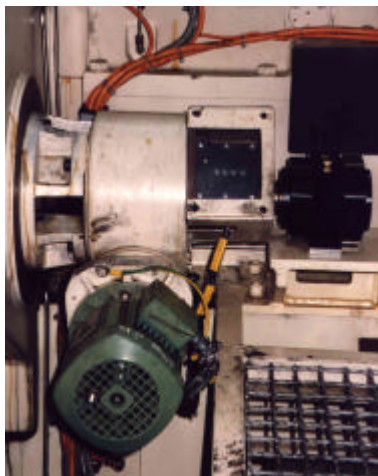

"REGU" accouplé à un vérin rotatif pneumatique à pignon crémaillère

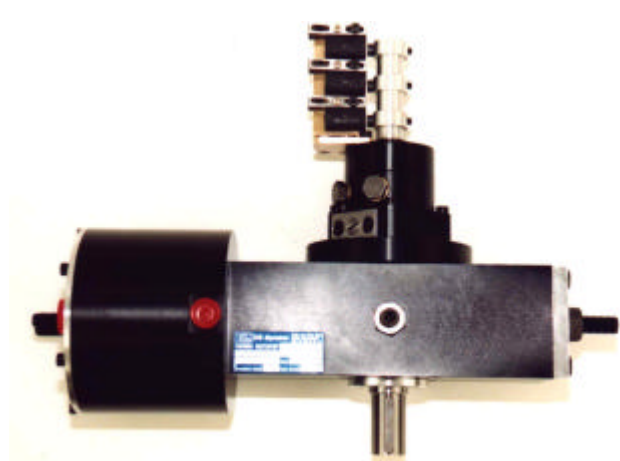

Principe de fonctionnement et de construction

Le "REGU" est construit sur la base d'un vérin rotatif hydraulique à palette, rempli d'huile, dont les alimentations sont obturées. Quand il est accouplé par sa sortie d'arbre à un vérin rotatif pneumatique, à un bras ou à toute autre force de rotation, la régulation du mouvement s'effectue quand l'huile du "REGU", poussée par la palette, passe d'une chambre à l'autre au travers d'une restriction réglable. Un compensateur est intégré afin d'absorber le surplus d'huile en cas de dilatation.

- arbre en acier monté sur roulement à billes
- corps et flasques en alliage d'aluminium traité par oxydation anodique dure
- pièces d'adaptation conçues pour différents types d'accouplement
- joints dynamiques en nitrile ou composites

spécifications techniques et encombrements

type	angle de rotation max. [°]	charge radiale max [N]	charge axiale max [N]	poids [Kg]	encombrements [mm]				
					A	B	C	D	E
REGU 1010	180	100	5	0,5	25	22	12	55	44
REGU 1020	260	1000	10	0,6	40	22	24	59	68
REGU 1030	260	2000	10	1,3	50	28	20	80	74
REGU 1060	260	2000	10	1,7	50	28	20	80	99
REGU 1100	280	6000	50	6	94	55	36	127	110
REGU 1190	280	6000	50	8,5	94	55	36	127	161

"REGUs" adaptés aux vérins rotatifs pneumatiques PCDY de DS dynatec

PCDY	REGU
PCDY 107 = 2 Nm	REGU 1010
PCDY 113 = 6 Nm	REGU 1010
PCDY 120 = 10 Nm	REGU 1010
PCDY 128 = 20 Nm	REGU 1020
PCDY 136 = 40 Nm	REGU 1030
PCDY 158 = 77 Nm	REGU 1060

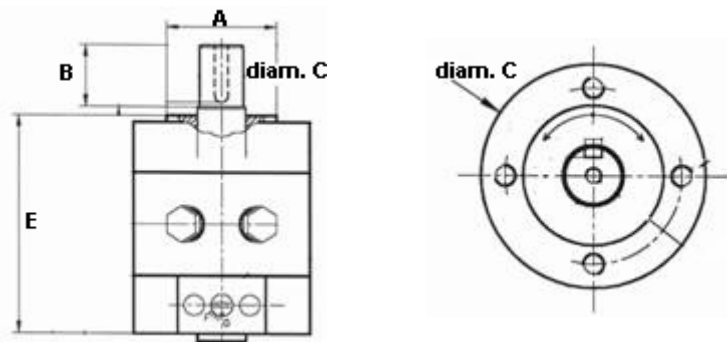

Accouplements standards du "REGU" au PCDY

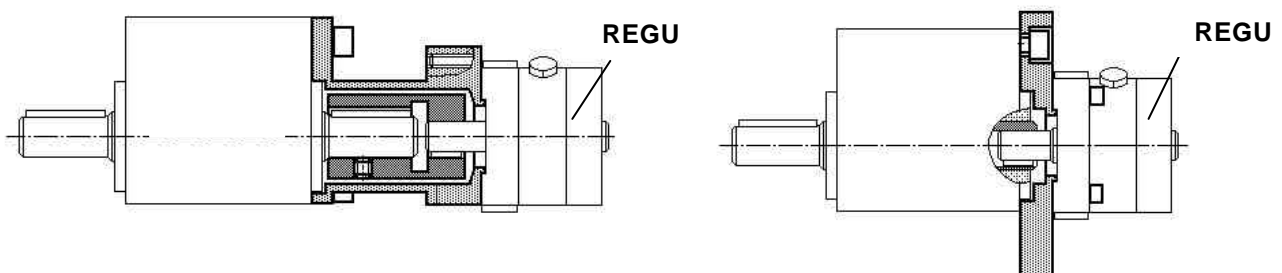

quelques exemples d'applications "REGU"

- neutraliser les effets de rebond

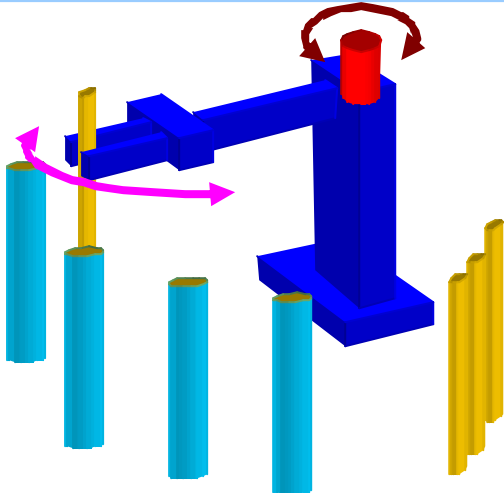

- contrôler l'accélération d'une charge portante oscillante

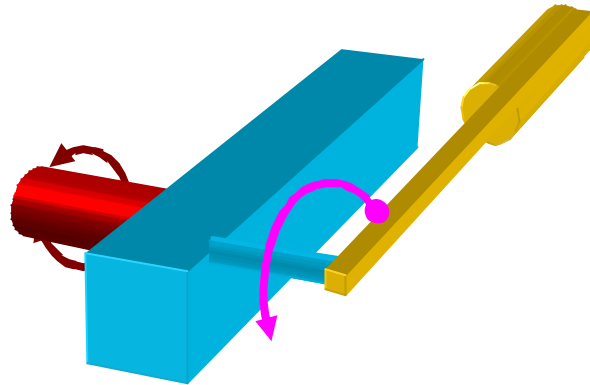

- amortir

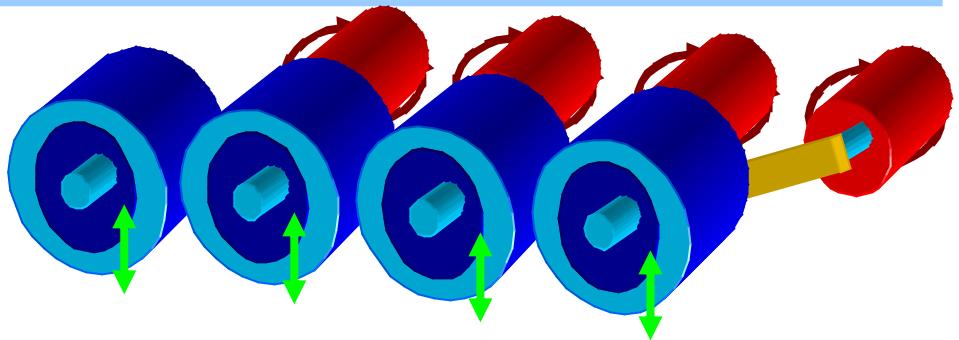

- récupérer un jeu de denture sur une transmission

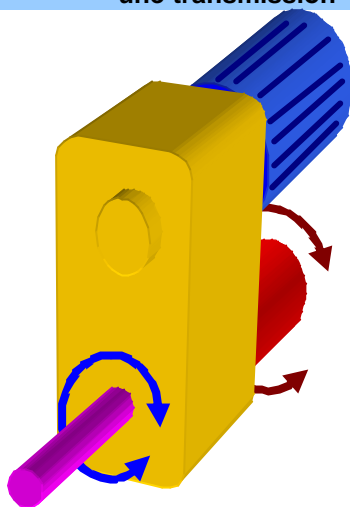

- freiner une inertie

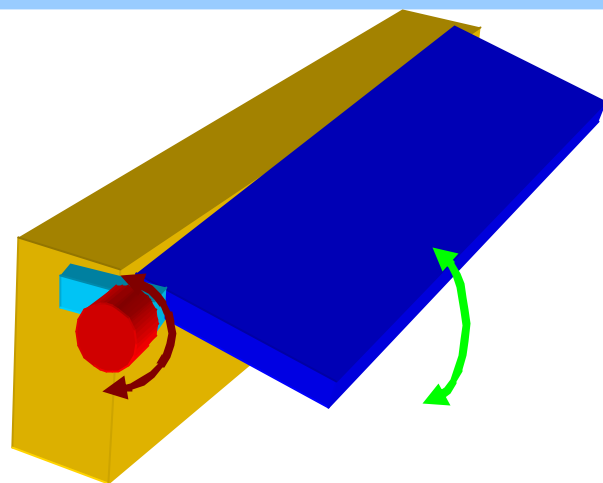



REGU

hydraulique *hydraulic*
caractéristiques techniques *performances*

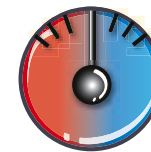

modèle <i>model</i>	rotation	couple moteur applicable <i>authorized torque</i> [Nm] max	charge maxi radiale <i>radial load max</i> [N]	charge maxi axiale <i>axial load max</i> [N]	cylindrée <i>volumetric</i> <i>displacement</i> [cm ³ /°]	poids <i>weight</i> [kg]	correspondances REGU → vérins rotatifs pneumatiques PCDY <i>PCDY pneumatic rotary actuator</i> → <i>corresponding REGU</i>	
REGU 1010	180°	10	100	5	0,027	0,5	PCDY 107 = 2 Nm	REGU 1010
REGU 1020	260°	20	1000	10	0,059	0,6	PCDY 113 = 6 Nm	REGU 1010
REGU 1030	260°	45	2000	10	0,128	1,3	PCDY 120 = 10 Nm	REGU 1010
REGU 1060	260°	85	2000	10	0,25	1,7	PCDY 128 = 20 Nm	REGU 1020
REGU 1100	280°	210	6000	50	0,62	6	PCDY 136 = 40 Nm	REGU 1030
REGU 1190	280°	420	6000	50	1,24	8,5	PCDY 158 = 77 Nm	REGU 1060

encombremments (en mm) *dimensions* (in mm)

modèle <i>model</i>	A	B	C	D	Ø E
REGU 1010	25	22	12	55	44
REGU 1020	40	22	24	59	68
REGU 1030	50	28	20	80	74
REGU 1060	50	28	20	80	99
REGU 1100	94	55	36	127	110
REGU 1190	94	55	36	127	161

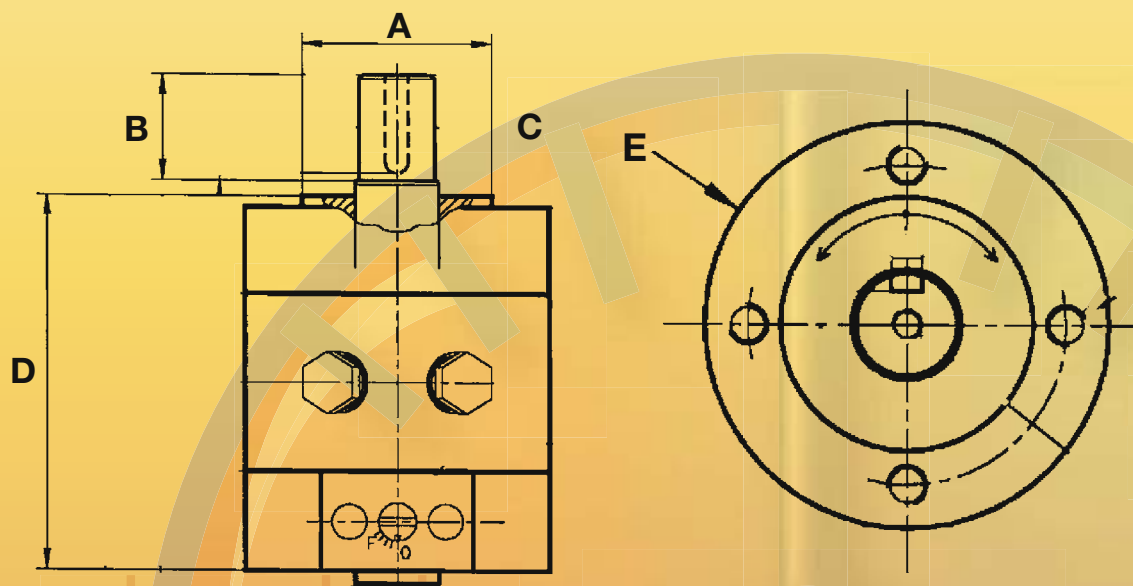

vérins rotatifs **REGU**

rotary actuators

vérins rotatifs

rotary actuators

vérins rotatifs

rotary actuators

régulateur hydraulique *hydraulic regulator*
quelques exemples d'applications *some examples of applications*

neutraliser les effets de rebond
for a bounce-free rotation



contrôler l'accélération d'une charge portante oscillante
to control the acceleration of an oscillating bearing load

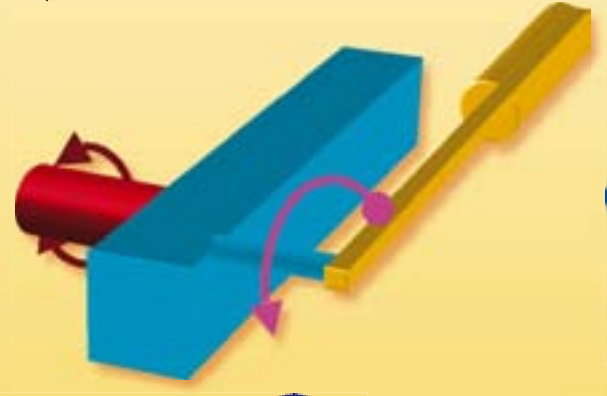

amortir
to damper



recupérer un jeu de denture
to recover a backlash on a transmission

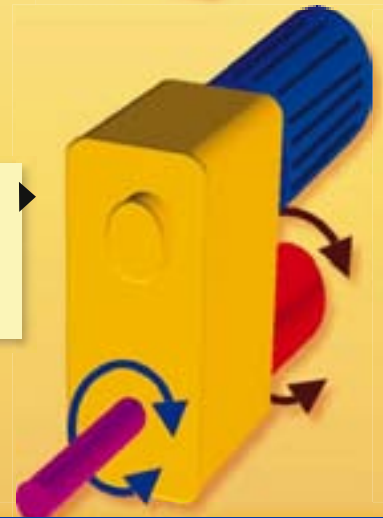

freiner une inertie
to slow down an inertia

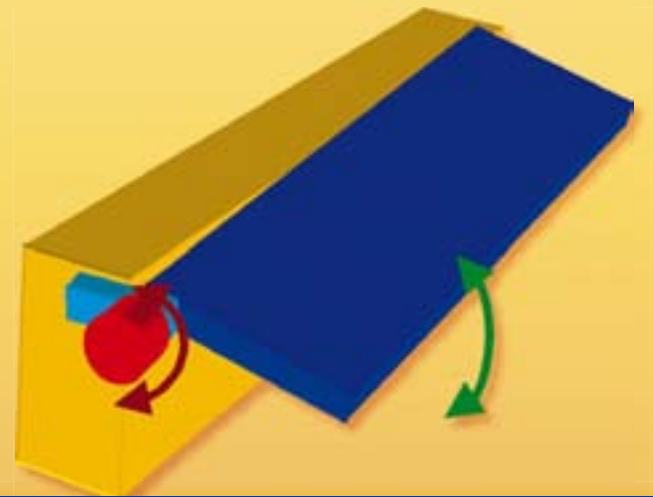

HRDA

Rotation 90°, 180°, 270° & 360° sur tous les modèles *for each size*

- pression nominale d'utilisation 210 bar *working pressure 210 bar (3000 Psi)*
- en option : amortisseurs hydrauliques intégrés, rattrapage angulaire $\pm 4^\circ$ et différents types de sortie d'arbre. *options: cushioning both ends, angle adjustment $\pm 4^\circ$, camshaft & hollow shaft*
- en standard une sortie d'arbre clavettée ou cannelée. *Single shaft extension (splined or keyed)*



caractéristiques techniques performances

modèle <i>model</i>	couple <i>torque</i> [Nm]	charge radiale <i>radial load</i> max [N]	charge axiale <i>axial load</i> max [N]	cylindrée <i>volumetric displacement</i> [dm³]				poids <i>weight</i> [kg]			
				90°	180°	270°	360°	90°	180°	270°	360°
HRDA 40	200	1567	8000	0,020	0,040	0,060	0,080	4	4,5	5	5,5
HRDA 50	340	2976	10000	0,033	0,066	0,099	0,132	5	5,8	6,9	7,4
HRDA 63	650	4364	14000	0,066	0,131	0,196	0,262	8,5	9,8	11	12,2
HRDA 80	1300	7875	19050	0,131	0,262	0,391	0,521	16,7	19,1	21,5	24
HRDA 100	2500	11250	24900	0,255	0,509	0,763	1,018	24,1	29,2	34	38,5
HRDA 125	5107	17552	34100	0,518	1,036	1,554	2,071	47	55	63,5	72,5
HRDA 140	7100	17800	34800	0,759	1,518	2,277	3,036	74	87	101	115
HRDA 160	11300	36300	46200	1,145	2,290	3,435	4,580	114	136	154	170
HRDA 180	16200	37600	47400	1,678	3,356	5,034	6,712	150	187	213	245
HRDA 200	22300	67210	62000	2,261	4,522	6,783	9,044	194	238	264	306
HRDA 225	32000	69000	63100	3,388	6,676	10,014	13,352	404	488	565	630
HRDA 225 S	38920	69000	63100	4,127	8,245	12,368	16,491	487	543	637	684
HRDA 250	44000	78000	66500	4,607	9,215	13,821	18,429	630	726	815	912
HRDA 280	60800	84600	71000	6,348	12,695	19,043	25,391	874	1011	1164	1292
HRDA 300	76000	89400	76000	7,930	15,862	23,79	31,724	1126	1308	1484	1677

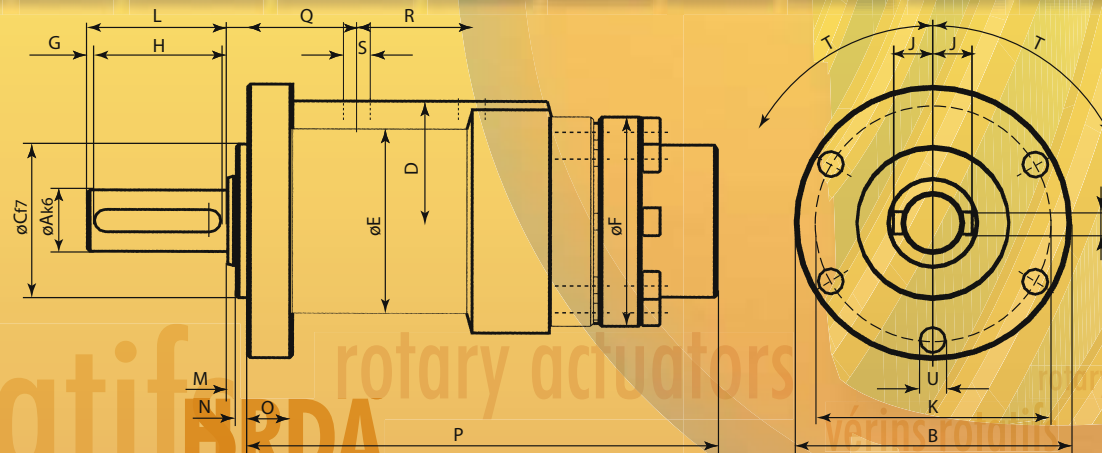

vérins rotatif HRDA

rotary actuators

rotary actuators

vérins rotatifs rotary actuators

encombremets (en mm) *dimensions (in mm)*

modèle <i>model</i>	ØA k6	ØA m6	ØB	ØC f7	ØF	I	J	K	L	M	N	O	Q
HRDA 40	22		98	55	75	8	14	84	50	3	4	16	39
HRDA 50	28		110	68	82	8	17	90	60	3	4	18	39
HRDA 63	35		128	80	95	10	20,5	108	80	3,5	5	25	48
HRDA 80	42		150	100	118	12	24	130	110	3	6	30	57
HRDA 100		55	178	115	147	16	31,5	155	110	4	6	31	65
HRDA 125		70	222	150	183	20	39,5	195	140	4	8	37	74
HRDA 140		80	250	160	210	22	45	220	150	7	10	40	78
HRDA 160		100	278	190	240	28	56	145	210	5	12	43	95
HRDA 180		105	298	210	270	28	58,5	265	210	5	12	45	125
HRDA 200		120	325	235	295	32	67	290	210	5	12	54	125
HRDA 225		140	385	260	350	36	78	345	260	6	15	64	155
HRDA 255 S		140	385	260	350	36	78	345	260	6	15	64	155
HRDA 250		150	450	300	385	36	83	400	300	6	20	90	224
HRDA 280		170	490	340	435	40	94	450	300	6	20	100	261
HRDA 300		180	555	380	470	45	100	500	300	6	20	110	271

modèle <i>model</i>	S G "	T °	U Nbr.	U	DIN 5480	P angle °				R angle °			
						90°	180°	270°	360°	90°	180°	270°	360°
HRDA 40	1/8"	60	5	9	W 22x1,25x16x8f	124	149	182	210	28	41	55	68,5
HRDA 50	1/8"	60	5	9	W 28x2x12x8f	133	164	200	232	31	48	65	80,5
HRDA 63	1/4"	60	5	11	W 35x2x16x8f	152	200	245	284	37	57	79	99
HRDA 80	3/8"	45	7	11	W 40x2x18x8f	187	240	290	345	47	74	101	125
HRDA 100	1/2"	45	7	14	W 55x2x26x8f	245	311	366	432	56,5	89	121,5	154
HRDA 125	1/2"	40	8	18	W 70x2x34x8f	281	392	480	550	76	118,5	162,5	207
HRDA 140	1/2"	40	8	18	W 80x3x25x8f	304	401	499	597	82	130	180	229
HRDA 160	3/4"	40	8	22	W 100x3x32x8f	365	474	593	707	110	168	224	285
HRDA 180	1"	30	11	22	W 105x3x34x8f	435	565	702	880	119	186	253	321
HRDA 200	1"	30	11	22	W 120x5x22x8f	440	587	730	878	128	202	273	346
HRDA 225	1"	22,5	15	22	W 140x5x26x8f	570	732	900	1069	159	240	321	403
HRDA 255 S	1"	22,5	15	22	W 140x5x26x8f	690	805	995	1220	175	276	381	484
HRDA 250	1"	22,5	15	26	W 150x5x28x8f	710	875	1060	1261	155	248	343	437
HRDA 280	1"	18	19	26	W 170x5x32x8f	790	1000	1205	1261	183	287	392	493
HRDA 300	1"	18	19	32	W 180x5x34x8f	840	1060	1285	1510	194	302	414	528



HRBV



- Rotation 140° + 4°
- pression nominale d'utilisation 150 bar — pression maxi de service 190 bar
nominal working pressure 150 bar — max working pressure 190 bar

modèle <i>model</i>	couple de rotation <i>torque</i> Nm	couple de maintien <i>holding torque</i> Nm	cylindrée dm ³ <i>volumetric displacement</i>	poids <i>weight</i> kg	poids du godet <i>weight of t</i>
HRBV 125	2000	4000	0,51	51	1,5 - 5
HRBV 140	3400	6800	0,84	88	4 - 7
HRBV 180	6950	13500	1,69	140	6 - 10
HRBV 225	10600	20000	2,76	184	9 - 13
HRBV 250	16200	30500	3,85	243	11 - 22
HRBV 270	23300	43800	5,41	382	23 - 29
HRBV 300	33200	63000	7,80	478	30 - 38

encombremments (en mm) *dimensions (in mm)*

	HRBV 125	HRBV 140	HRBV 180	HRBV 225	HRBV 250	HRBV 270	HRBV 300
A	305	380	440	450	490	580	623
B	255	330	380	380	420	500	523
C	Ø 175	Ø 205	Ø 245	Ø 278	Ø 308	Ø 352	Ø 380
D	Ø 150	Ø 180	Ø 210	Ø 250	Ø 280	Ø 320	Ø 350
E	Ø 180	Ø 210	Ø 250	Ø 285	Ø 315	Ø 360	Ø 390
F	110	130	150	180	220	250	270
G	102	115	140	160	175	200	215
H	140	165	190	220	250	280	300
I	2 x 12 M10x16	2 x 12 M12x18	2 x 12 M16x24	2 x 12 M20x25	2 x 12 M20x30	2 x 12 M27x40	2 x 12 M27x40
J	8 M14x18	10 M14x21	10 M20x30	12 M24x40	12 M24x40	12 M30x40	12 M30x40
K	100	120	75	185	200	220	240
M	30°	30°	30°	30°	30°	30°	30°
N	50	65	70	110	105	75	95
O	40	45	55	45	50	50	50
P	75	50	60	50	80	140	175

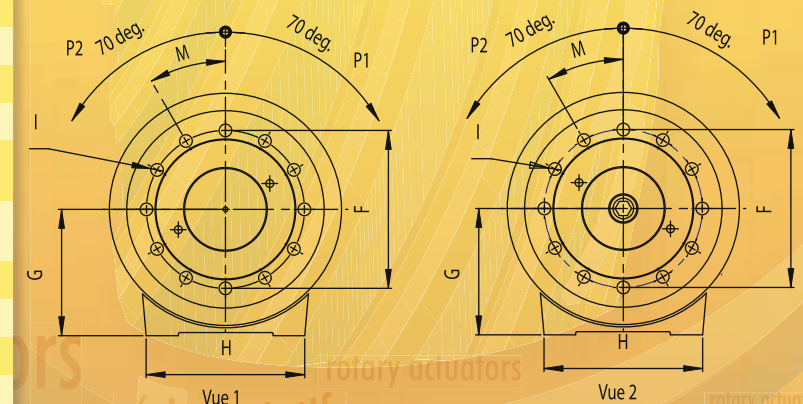
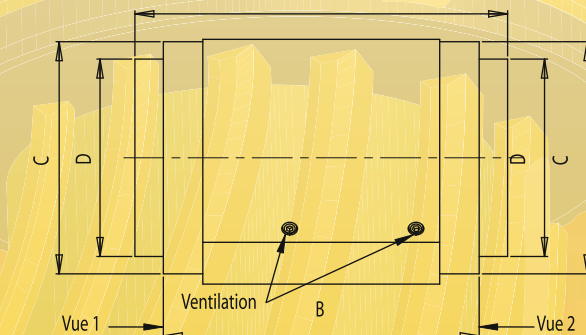
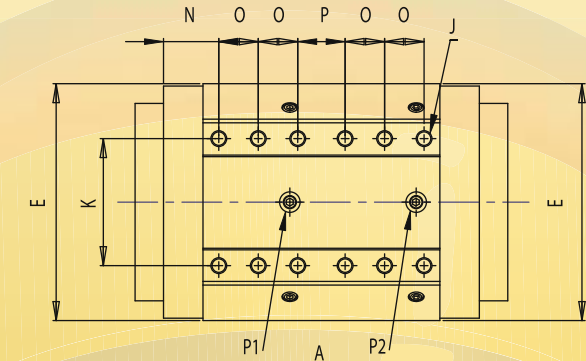



HRMD

- Rotation 180° & 360°
- pression nominale d'utilisation 210 bar *working pressure 210 bar*
- Arbre creux en standard pour passer un tirant ou des conduites hydrauliques ou électriques.

In standard with center clearance hole through the entire length of the shaft, convenient passage for piston rod, hydraulic hoses or electrical wires



caractéristiques techniques & dimensions performances & dimensions

modèle model	angle de rotation rotation angle	couple maxi max torque 210 bar 3000 Psi IN-LB / Nm	charge maxi axiale axial load max [N]	charge maxi radiale* radial load max* [N]	poids weight [Kg]		cylindrée volumétric displacement [dm³]		Ø A mm		Ø B mm		C		Ø D mm Qty x Thread	Ø E mm Qty x Thread
					180° LB/Kg	360° LB/Kg	180°	360°		180°	360°	180°	360°			
HRMD 50	180° & 360°	1,700 / 190	9000	9000	16,3 / 7,4	./.	0,073		100	14		139,7		54 (8xM8)	86 (8xM8)	
HRMD 60	180° & 360°	3,000 / 340	13500	13500	23,4 / 10,6	30 / 13,6	0,122	0,19	119,3	16,7	17,15	143	189,3	73 (8xM8)	103,2 (8xM8)	
HRMD 63	180° & 360°	5,500 / 720	18000	18000	31,8 / 14,4	41,5 / 18,8	0,192	0,312	135	21	22	155,7	212,1	80 (12xM10)	117 (12xM10)	
HRMD 70 -FU	180°	4,500 / 500	4900	13500	28,2 / 12,8	./.	0,131	./.	104		19,3	188	./.	54 (6xM 10)	116	
HRMD 80	180° & 360°	9,500 / 1,073	36000	36000	58,5 / 26,5	79,5 / 36	0,346	0,554	169,9		35,7	184,2	258	102 (12xM12)	151 (12xM12)	
HRMD 85-FU	180°	8,200 / 930	6700	21000	36,5 / 16,6	./.	0,221	./.	117		25,4	215,9	./.	66,7 (8xM10)	139,7	
HRMD 90	180° & 360°	15,000 / 1,700	49000	49000	95 / 43	120 / 54,4	0,55		197		45,7	224	311	127 (12xM12)	175 (12xM12)	
HRMD 100	180° & 360°	25,660 / 2,900	66800	66800	125 / 56,7	180 / 81,6	0,715	1,43	225,5		66,8	238,5	346,4	140 (12xM16)	203 (12x M12)	
HRMD 120-FU	180°	15,000 / 1,690	10000	41000	66 / 30	./.	0,421	./.	142		25,4	247,5	./.	85,7 (8xM12)	152,4	
HRMD 125-FU	180°	26,000 / 2,940	9000	55000	115 / 52	./.	1,16	2,31	170		1"-8 UNC-2B	298,5	./.	101,6 (8xM20)	184,2	
HRMD 145-FU	180°	39,000 / 4,400	11000	93800	170 / 77	./.	./.	./.	195		1"-1/4-7 UNC-2B	336,6	./.	120,7 (8xM30)	216	

*Charge radiale sur la bride d'entraînement

*Radial load on shaft flange

encombrements (en mm) dimensions (in mm)

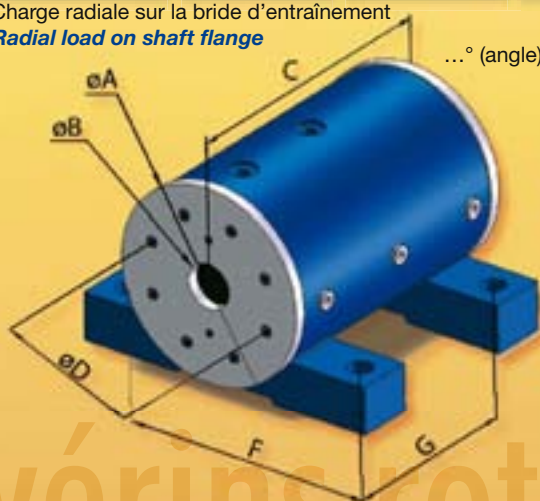

HRMD ... (taille size)
...° (angle) - FU sur pieds *foot mounting*

HRMD ... (taille size) - ...° (angle) - sur flasque *flange mounting*

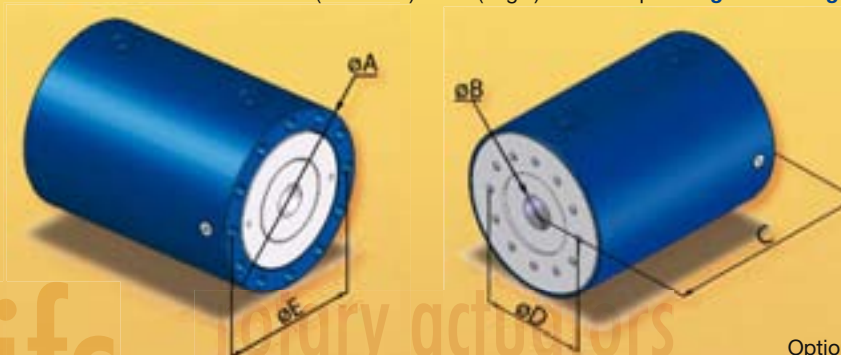

	F mm	G mm
HRMD 70 -FU	142	66
HRMD 85-FU	152,4	76,2
HRMD 120-FU	197	86
HRMD 125-FU	222	108
HRMD 145-FU	266,5	120,7



Option : HRMD vanne d'équilibrage - *counterbalance valve*

HRSA



- rotation $90^\circ \pm 1^\circ$ sur tous les modèles *for each size*
- pression nominale d'utilisation 210 bar *working pressure 210 bar (3000 Psi)*
- en standard arbre creux simple/double clavette, à section carrée ou à méplats (norme DIN). *Standard hollow shaft with 1 / 2 feather key, square or double*
- en option: commande manuelle de secours, amortisseurs hydrauliques intégrés, capteurs inductifs ou mécaniques ou de proximité intégrés, réglage d'angle.
options: emergency operation, cushioning both ends, limit switches (mechanical or induced proximity), rotation angle adjustment.



caractéristiques techniques performances

modèle <i>model</i>	couple <i>torque</i> [Nm/bar]	Couple maxi <i>max torque</i> Nm [210 bar]	cylindrée <i>volumetric displacement</i> [dm ³]	pois <i>weight</i> [kg]	T mm	O mm	P mm	P1 mm	N mm	B mm	S (")	R mm
HRSA 30	0,3	63	0,009	5,6	10	11	99	114	10	70	G1/8	35
HRSA 42	0,95	200	0,022	6,9	15	18	137	157	15	114	G1/8	37
HRSA 55	2,1	441	0,038	8,2	20	18	159	179	15	124	G1/4	48
HRSA 63	3	630	0,081	12	25	25	187	208	15	128	G3/8	63
HRSA 80	7,2	1512	0,164	20,6	25	25	216	236	15	150	G3/8	75
HRSA 100	14,7	3087	0,366	27,7	25	31	252	272	15	178	G3/8	88
HRSA 125	22	4620	0,484	47	25	37	285	305	15	222	G3/8	77
HRSA 140	30	6300	0,719	74	25	40	304	324	15	250	G3/8	82
HRSA 160	50	10500	1,099	114	25	43	365	385	15	278	G3/8	110
HRSA 180	71	14910	1,626	150	25	45	435	455	15	298	G1/2	119
HRSA 200	100	21000	2,179	194	30	54	440	460	15	325	G1/2	128
HRSA 225	142	29820	3,271	354	40	64	570	590	15	385	G3/4	159
HRSA 225S	175	36750	4,039	462	45	64	690	720	15	385	G3/8	175
HRSA 250	200	42000	4,532	551	50	90	710	730	15	450	G1	155
HRSA 280	275	57750	6,268	764	50	100	790	810	15	490	G1	183
HRSA 300	350	73500	7,843	1100	50	100	840	860	15	555	G1	194

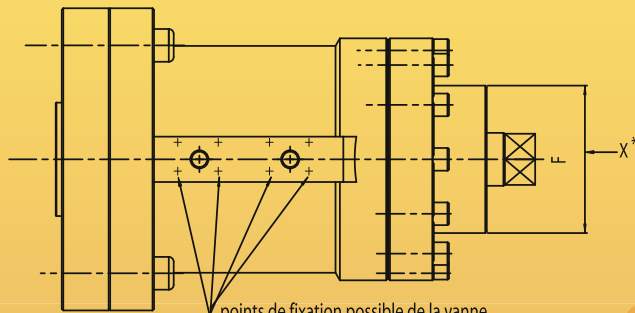

points de fixation possible de la vanne
possible fixation points for the valve

* types de bride (voir ci-dessous)
flange types (below)
dimensions acc.
DIN ISO 5211

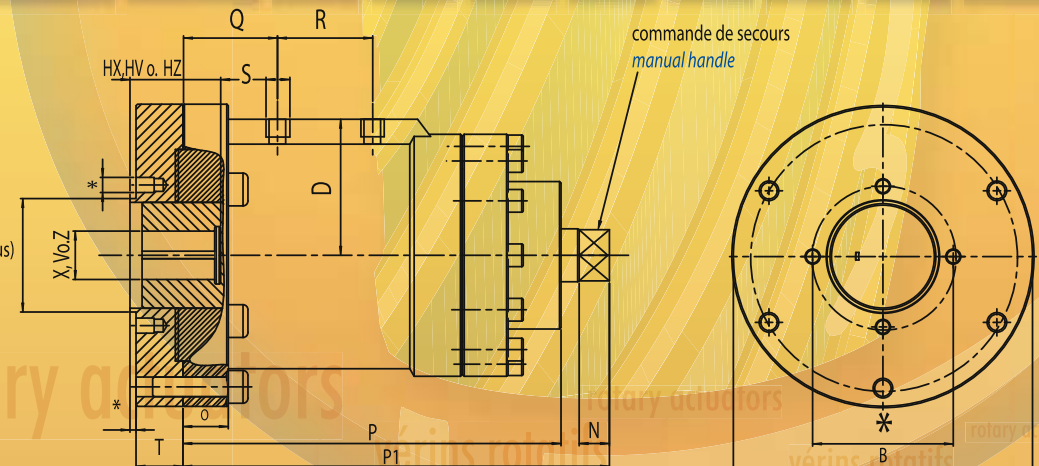

commande de secours
manual handle

vérins rotatif HRSA

rotary actuators

modèle model	HWP X1 mm	X2 mm	X3 mm	HX mm	HWV SW V mm	V1 mm	HV mm	HWZ SW Z mm	Z1 mm	HZ mm
HRSA 30	12	4	7,8	31	12	17	34	10	17	34
HRSA 42	18	6	11,8	39	17	24	34	12	24	34
HRSA 55	20	6	12,8	45	18	25	45	14	25	45
HRSA 63	20	6	12,8	45	18	25	45	14	25	45
HRSA 80	30	8	18,3	75	26	36	50	22	36	50
HRSA 100	42	12	24,3	100	35	50	50	30	50	50
HRSA 125	55	16	31,8	120	50	71	50	36	71	50
HRSA 140	60	18	34,4	120	50	71	50	41	71	50
HRSA 160	75	20	42,4	150	67	95	60	55	95	60
HRSA 180	75	20	42,4	150	67	95	60	55	95	60
HRSA 200	95	25	52,9	175	82	116	70	65	116	70
HRSA 225	100	28	56,4	175	82	116	75	70	116	75
HRSA 225S	100	28	56,4	175	82	116	75	70	116	75
HRSA 250	110	28	61,4	175	95	135	85	80	135	85
HRSA 280	120	32	67,4	200	104	138	90	85	138	90
HRSA 300	140	36	78,4	200	120	170	100	95	170	100

HWP

à double clavette (DIN 6885)
with 2 feather key slots DIN 6885

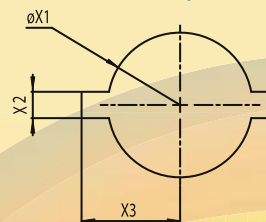

HWP 1

à simple clavette (DIN 6885)
with 1 feather key slot DIN 6885

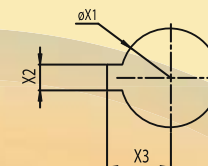

HWV

à section ISO carrée (DIN 475 T1)
ISO-Square DIN 471 T1

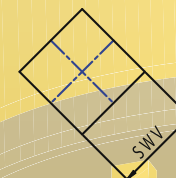

HWZ

à méplats ISO (DIN 475 T1)
ISODouble DIN 471 T1

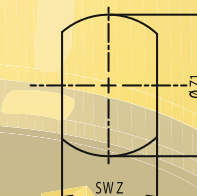

dimensions des brides **flanges dimensions** - (DIN ISO 5211)

bride flange	Ø d1 mm	Ø d2f8 mm	Ø d3 mm	Ø d4 mm	h max mm	nbr. vis nbr. screws	couple torque (Nm)
F03	46	25	36	M5	2	4	32
F04	54	30	42	M5	2	4	63
F05	65	35	50	M6	3	4	125
F07	90	55	70	M8	3	4	250
F10	125	70	102	M10	3	4	500
F12	150	85	125	M12	3	4	1000
F14	175	100	140	M16	4	4	2000
F16	210	130	165	M20	5	4	4000
F25	300	200	254	M16	5	8	8000
F30	350	230	298	M20	5	8	16000
F35	415	260	356	M30	5	8	32000
F40	475	300	406	M36	8	8	63000
F48	560	370	483	M36	8	12	125000

Part-turn actuator

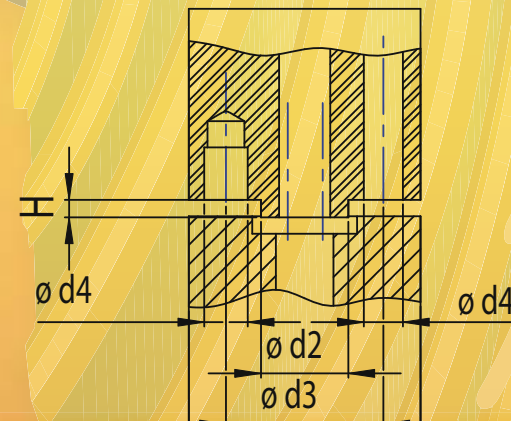



PCDY

pneumatiques *pneumatic* caractéristiques techniques *performances*



modèle <i>model</i>	rotation		couple <i>torque</i> [Nm]		charge maxi radial <i>radial load max</i> [N]	charge maxi axiale <i>axial load max</i> [N]	cylindrée volumetric displacement [cm ³ /°]	clavette <i>key</i>	poids <i>weight</i> [kg]	
			5 bar 75 PSI	10 bar 150 PSI						
PCDY 102 A	95°	185°	0,4	0,8	10	5	0,015		0,2	0,2
PCDY 107 A	95°	185°	2	4	100	50	0,074	disque 3x5	0,5	0,6
PCDY 113 B	240°	365°	5	10	1000	5	0,22	4x4x20	1,2	1,3
PCDY 120 D	400°		5	10	100	50	0,2	disque 3x5	1,5	
PCDY 113 A	95°	185°	6	12	1000	5	0,28	4x4x20	1	1,2
PCDY 120 B	240°		7	14	700	5	0,35	4x4x20	1,6	
PCDY 120 C	275°		7	14	700	5	0,31	4x4x20	1,5	
PCDY 120 A	95°	185°	10	20	700	5	0,43	4x4x20	1,3	1,6
PCDY 128 C	375°		13	26	2000	200	0,5	4x4x20	1,6	
PCDY 128 B	240°		16	32	30000	10	0,61	6x6x36	2,9	
PCDY 128 A	95°		20	40	30000	10	0,78	6x6x36	2,6	3
PCDY 136 C	375°	185°	20	40	4000	10	0,78	6x6x36	4,3	
PCDY 136 B	280°		25	50	5000	10	1	6x6x36	4,5	
PCDY 158 C	375°		38	76	5000	10	1	6x6x36	7	
PCDY 136 A	95°	185°	40	80	5000	10	1,56	6x6x36	3,7	4,5
PCDY 158 B	280°		50	100	5000	10	1	6x6x36	7,1	
PCDY 158 A	95°	185°	77	154	5000	10	3,05	6x6x36	6	7,2

encombres (en mm) *dimensions (in mm)*

PCDY	A	B	C	D	E	F	G	H	I	J	K	L	M	N	O	P	Q	R	S	T	U	V	W	X	Y	Z
102 A	76,5	25		10		8	16	9	0,8		12			3xM4	6	18		9	4xM4	6	M4					1/8
107 A	72/92	40		10g6	41	12	14js9	10	2		14			3xM5	8	20		16	4xM5	8	M4	20	M4	6	10	1/8
113 B	194/153	50	22	14g6	50	17	28f7	15	3		3xM6	50		3xM6	10	32		20	4xM6	10	M8	17	M5	8		1/8
120 D	177	60	22	14g6	52,5	22	28h7	15		2	22			3xM6	10	32		20	4xM6	10	M8	20	M5	2	18	1/4
113 A	115/153	50	22	14g6	50	17	28f7	15	3		3xM6	50		3xM6	10	32		20	4xM6	10	M8	17	M5	8		1/8
120 B	177	60	22	14g6	52,5	22	28h7	15		2	22			3xM6	10	32		20	4xM6	10	M8	20	M5	8	18	1/4
120 C	177	60	22	14g6	52,5	22	28h7	15		2	22			3xM6	10	32		20	4xM6	10	M8	20	M5	8	18	1/4
120 A	134	60	22	14g6	52,5	22	28h7	15		2	22			3xM6	10	32		20	4xM6	10	M8	20	M5	8	18	1/4
128 C	224	70	22	14g6	64	26	52g6	15	6		28		19	3xM8	12	40		28	4xM8	12	M12	35	M5	8	18	1/4
128 B	224	70	38	18h7	38	26	52g6	20	5,5		28		19	3xM8	12	40		28	4xM8	12	M12	35	M5	8	18	1/4
128 A	164/224	70	38	22h7	38	26	52g6	25	5,5		28		19	3xM8	12	40		28	4xM8	12	M12	35	M5	8	18	1/4
136 C	286	80	38	18h7	79	31	54f7	25	3,5		30		24	3xM8	14	50		30	4xM8	14	M16	35	M6	12	25	3/8
136 B	286	80	38	22h7	83	31	54f7	25	3,5		30		24	3xM8	14	50		30	4xM8	14	M16	35	M6	12	25	3/8
158 C	338	100	38	22g6	83	39	54h8	25		2	30		24	3xM8	12	55	65	38	8xM8	14	M16	35	M6	12	32	1/2
136 A	208/286	80	38	22h7	83	31	54f7	25	3,5		30		24	3xM8	14	50		30	4xM8	14	M16	35	M6	12	25	3/8
158 B	338	100	38	22g6	83	39	54h8	25		2	30		24	3xM8	12	55	65	38	8xM8	14	M16	35	M6	12	32	1/2
158 A	242/338	100	38	22g6	83	39	54h8	25		2	30		24	3xM8	12	55	25	38	8xM8	14	M16	35	M6	12	32	1/2



vérins rotatifs

rotary actuators

rotary actuators
vérins rotatifs

rotary actuators

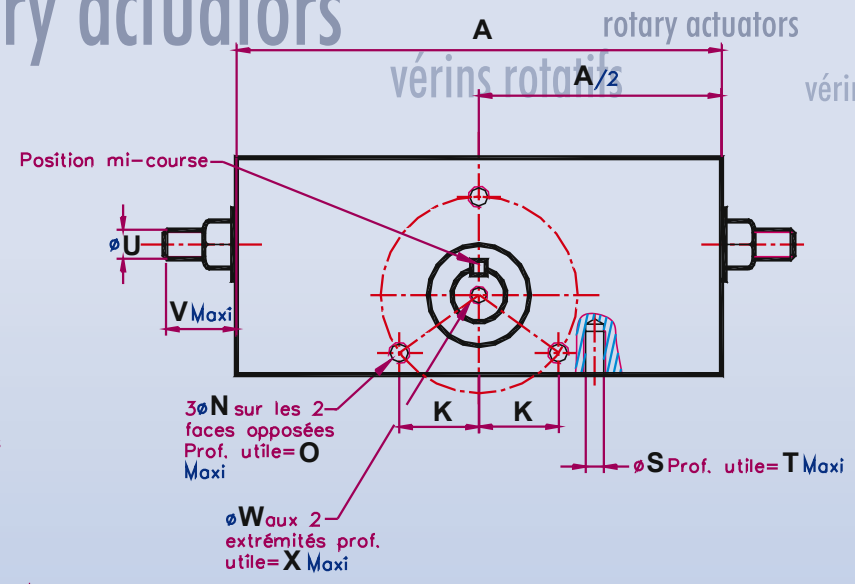
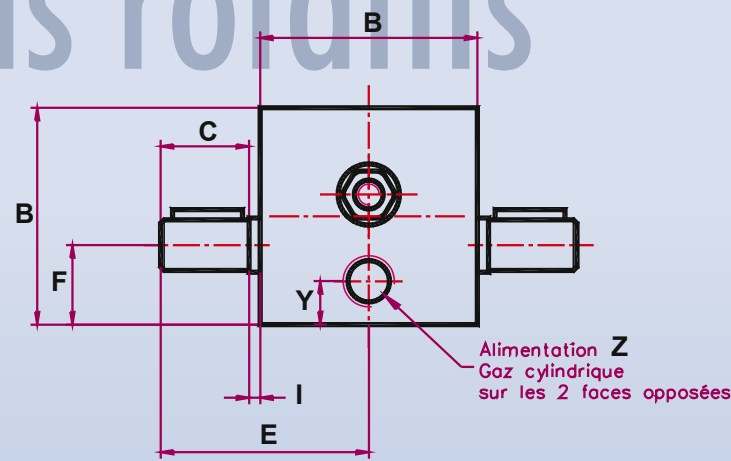

$4\phi N$
sur les 2 faces opposées
Prof. utile O_{Maxi}

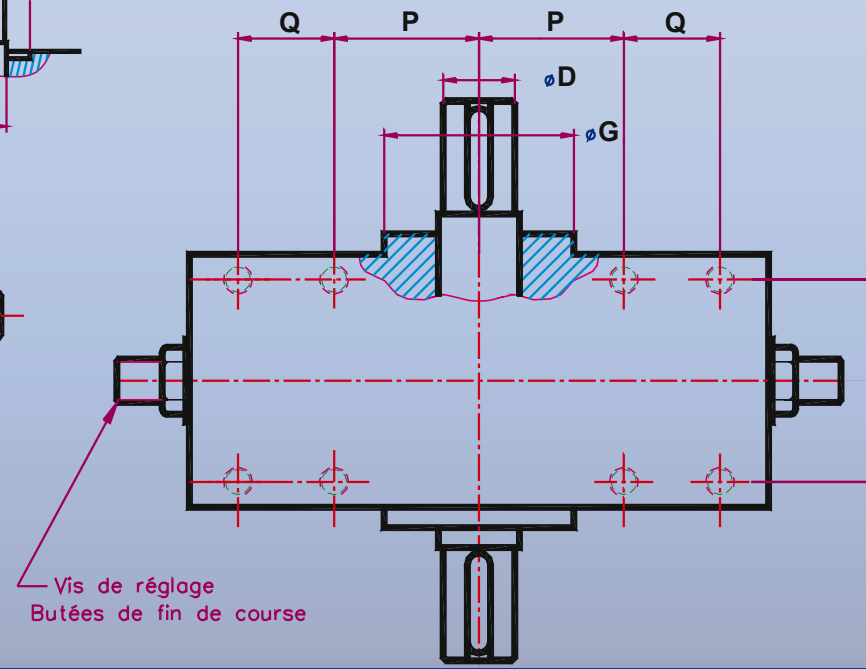
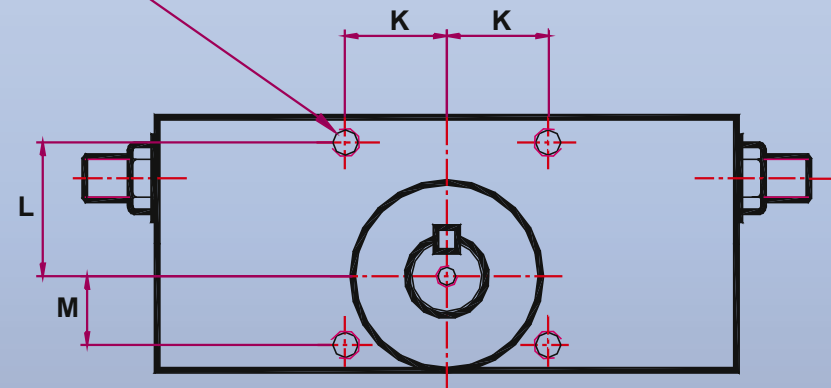
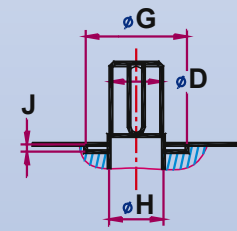



LP

pneumatiques *pneumatic* caractéristiques techniques *performances*



• simple palette *single vane*

modèle <i>model</i>	rotation	couple torque (Nm)		charge maxi axiale <i>axial load max</i> [N]	cylindrée volumetric displacement [cm ³ /°]	pression de décolage <i>break max</i>	fuite interne maxi à 7 bar <i>by-pass leakage at 100 PSI</i> [cm ³ /mn]	poids <i>weight</i> [kg]
		5 bar 75 PSI	10 bar 150 PSI					
LP-11	270°	0,8	1,9	36	0,05	1	5665	0,26
LP-12	270°	1,8	4	36	0,1	0,8	5665	0,34
LP-22	270°	4,6	10	55	0,23	0,7	5665	0,96
LP-24	270°	9,5	20,3	55	0,46	0,7	5665	1,4
LP-33	270°	14,5	31	180	0,6	0,7	7080	3
LP-35	270°	29,5	63	180	1,2	0,7	7080	4,4
LP-43	280°	54,4	114	230	2,15	0,7	8500	6,4
LP-47	280°	112	233	230	4,3	0,7	11330	9
LP-76	280°	230	474	450	9	0,6	12740	21
LP-712	280°	470	970	450	18	0,6	12740	30
LP-718	280°	707	1446	450	27	0,6	12740	40

• double palette *double vane*

modèle <i>model</i>	rotation	couple torque (Nm)		charge maxi axiale <i>axial load max</i> [N]	cylindrée volumetric displacement [cm ³ /°]	pression de décolage <i>break max</i>	fuite interne maxi à 7 bar <i>by-pass leakage at 100 PSI</i> [cm ³ /mn]	poids <i>weight</i> [kg]
		5 bar 75 PSI	10 bar 150 PSI					
LP-11	90°	2,1	4,8	36	0,1	0,8	7080	0,28
LP-12	90°	4,8	10,4	36	0,2	0,7	7080	0,37
LP-22	90°	10,6	22,8	54	0,46	0,7	7080	1
LP-24	90°	23,6	50,9	54	0,93	0,7	7080	1,5
LP-33	90°	30,5	64,4	180	1,21	0,7	8500	3,3
LP-35	90°	62,1	130	180	2,4	0,7	8500	5
LP-43	100°	115	240	230	4,3	0,7	9900	7
LP-47	100°	234	484	230	8,6	0,7	12460	10
LP-76	100°	489	1006	450	18	0,6	12740	23
LP-712	100°	978	2012	450	36	0,6	12740	33
LP-718	100°	1510	max 8 bar	45	54	0,6	12740	44

encombrements (en mm) *dimensions (in mm)*

	LP11	LP12	LP22	LP24	LP33	LP35	LP43	LP47	LP76	LP712	LP718		LP11	LP12	LP22	LP24	LP33	LP35	LP43	LP47	LP46	LP712	LP 718
A	101,6	127	160,5	211,3	203,2	266,7	247,8	336,7	406,4	558,8	711,2	QE	12,19		16,51		-						
B	80,77	106,2	133,3	184,2	161,8	225,3	203,2	292,1	320,8	473,2	625,6	QT	11,17		16,51		16,76		20,6		34,92		
C		25,4		35,81		44,45		47,5		88,9		T		-			44,45		66,68		101,6		
D	44,5	69,85	77,72	128,5	101,6	165,1	136,1	225	209,6	362	495,3	V		-			31,75		42,93		66,68		
GJ		11,18		19,05								Y	21,34			31,75		38,1		53,85		82,55	
H		2,29		3,05								AA		-			1/4-20		3/8-16		1/2-13		
J					88,9	152,4	120,4	209,3	190,5	342,9	495,3	BB	52,32			77,72		88,9		133,35		203,2	
K						12,7		15,75			19,05	CC	21,34			31,75		38,1		82,55			
L	1,59 x 12,7		3,18 x 15,88		6 x 3		8 x 4				12,7 x 6,35	LL	12,7			19,05		25,4		31,75		38,1	
M	9,65		12,7		28,45		25,4				44,45	MM	5,33			6,86		7,11		10,41		13,46	
N	9,487		15,837		25,387		31,74				50,762	NN	50,8	76,2	88,9	139,7	114,3	177,8	152,4	241,3	228,6	381	533,4
PE		1/8-27 NPTF										RR	15,24			21,59							
PT		-			1/8-27 NPTF		1/4-18 NPTF				3/8-18 NPTF	SS	10-24 UNC x12,7			1/420 UNC x15,7							

Côté gauche LP 11 *Left Side*

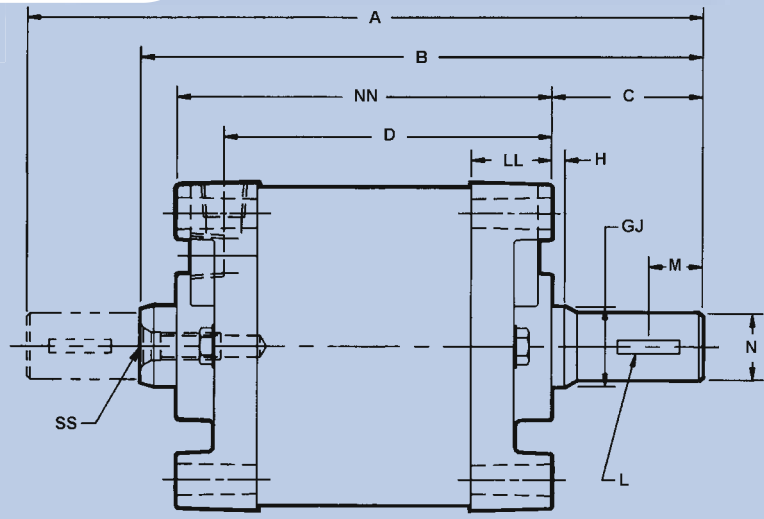

LP 11 *Right Side*

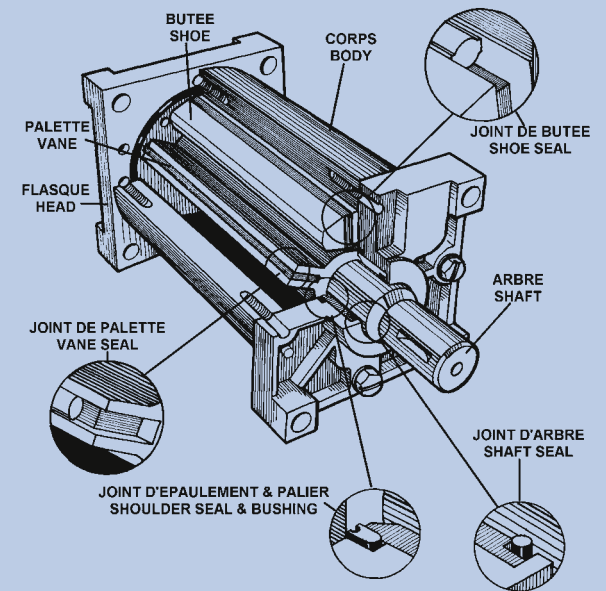
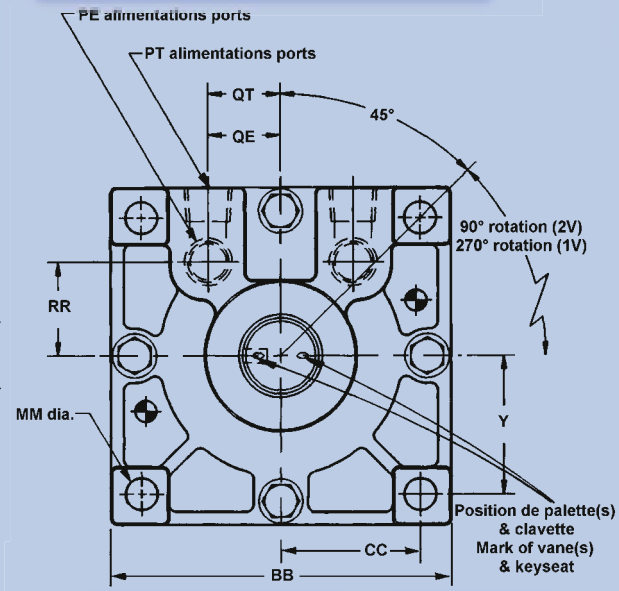

Côté gauche LP 33 *Left Side*

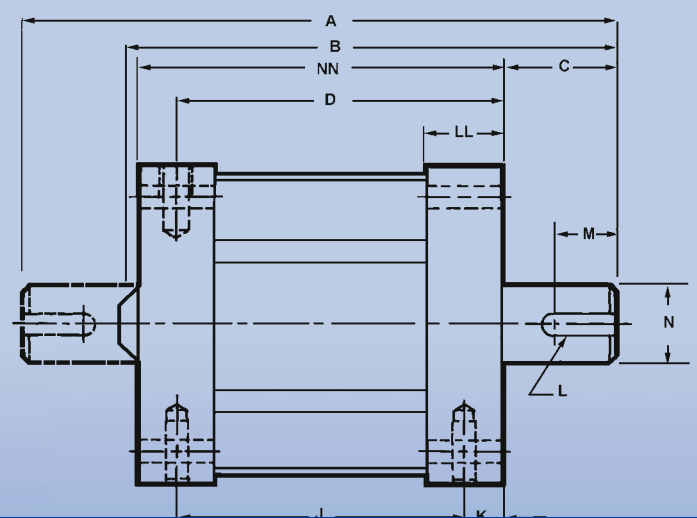

LP 33 *Right Side*

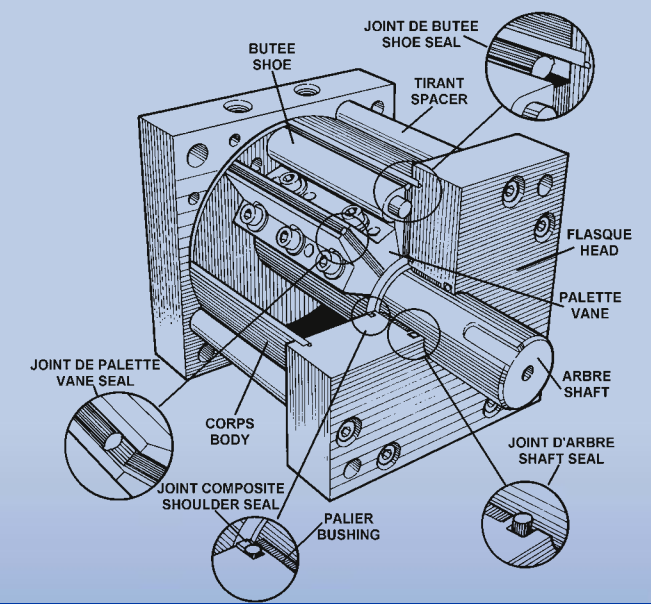
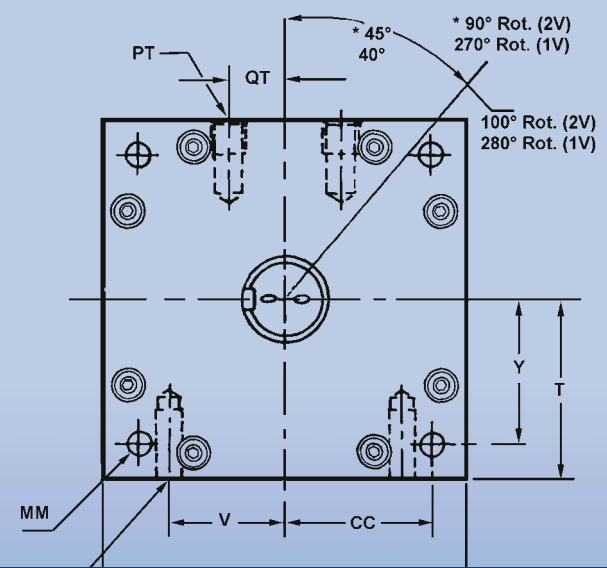



+34 943 377 740



info@diprax.es



www.diprax.es

Polígono Industrial Belartza, Gurutzegi Kalea, 17 Pab. D4 y D5, 20018 - Donostia - San Sebastián