



Take a Stand

The FEZER working stands are the ideal addition for your production process. Treat workpieces all around, move them, or work on them stationarily - the device series VacuStand offers the suitable solution.

VacuStand I+II	97/98
VacuStand 180E	99/100
Application Examples and Details	101/102
MobiLift	103/104

Working Stands

VacuStand VS-I and VS-II

Working Stands with Rotation and Swivel Unit

The working stands distinguish themselves by their light, but very robust design. When placing a workpiece on the stand it is automatically engaged by a touch valve. On the VS-I workpieces can be swivelled by 90° in one direction and rotated endlessly. On the VS-II both-sided swivelling by 90° is possible. The workpieces are released via foot control with safety cover. Different suction pads and attachments are available for both lifter designs.

- Single suction pad or attachment with up to 4 suction pads
- Eco Module for vacuum-controlled pump operation
- Arrest modules with foot control for swivelling and rotation
- Special designs with pneumatical drives for rotation and swivelling

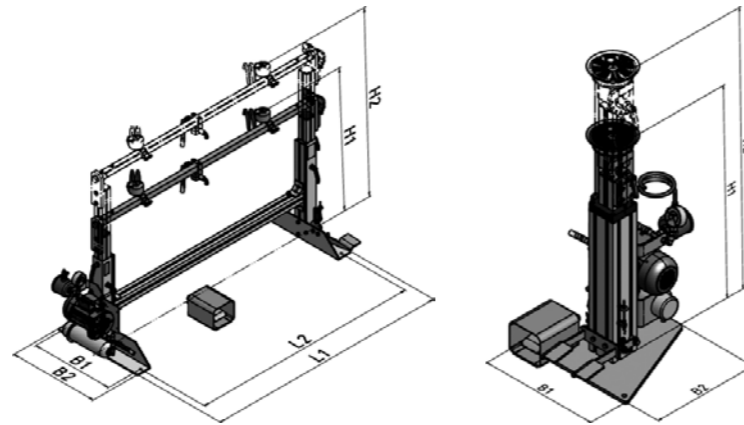

Type	Design	Pump	Voltage (V, Hz)	Swivelling (°)	Rotation (°)	L1 (mm)	L2 (mm)	B1 (mm)	B2 (mm)	H1 (mm)	H2 (mm)	Own weight (kg)
VA I-AL-TV	Table attachm.	T 4.4	230, 50	90	endless	---	---	---	---	---	---	5 ... 15
VS I-AL	Single-foot	T 4.4	230, 50	90	endless	---	---	435	400	770	1.025	45 ... 65
VS II-AL 2	Double-foot	T 4.4	230, 50	90	---	1.175	1.265	460	500	1.000	750	65 ... 85
VS II-AL 3	Double-foot	T 4.4	230, 50	90	---	1.175	1.265	460	500	1.000	750	65 ... 85
VS II-AL 4	Double-foot	T 4.4	230, 50	90	---	1.175	1.265	460	500	1.000	750	65 ... 85

Suction pads/Attachment	FSRL 120	FSRL 170	FSRL 230	FSRL 290	FSL 100x200	FSL 100x300	Attachment II	Attachment IV
Suitable for:	VS I / VS II	VS I / VS II	VS I / VS II	VS I / VS II	VS I / VS II	VS I / VS II	VS I	VS I
Dimension:	D=120	D=170	D=230	D=290	100x200	100x300	820x200x110	820x400x150
Holding force (kg) hor.	25	50	100	150	40	65	depending on suction pad	
Holding force (kg) vertical	13	25	50	75	20	33	depending on suction pad	

VacuStand VS in Action

- 1 VacuStand VS-I with double attachment for treating aluminum diecast parts
- 2 VacuStand VS-I for treating stone slabs
- 3 Handling glass panes for installation on vehicle cabins
- 4 VacuStand VS-I with fourfold attachment and battery

Working Stands

VacuStand VS-II-180

Stationary Turning Station with Swivel Drive

For integration in running processes where loads have to be turned over the stationary turning stations by FEZER offer a multitude of advantages. The vacuum technology can safely engage workpieces within seconds and release them after swivelling. Depending on the requirements turning times of up to 30 seconds can be realized. Individual designs can adjust the turning stations perfectly to your production processes and guarantee a rational and efficient process optimization

- Electrical turning of workpieces
- Control of all functions by push-buttons on a control panel
- Turning process by electric motors with automatic final position switch-off
- Integration of tensioning, movement or clamping attachments
- Electrical height regulation for adjustment to different widths during the turning process
- Individual construction adjustment for perfect process optimization



Height adjustment and FU-regulated swivel drive of a turning station



Control panel with all function buttons, main switch, and emergency-off



Regulation axis with pneumatic cylinder and precision guide elements

VacuStand VS-180E in Action

- 1** with height adjustment, both-sided swivel drive and pneumatical width adjustment
- 2** for turning 16.000 mm long lorry side panels with a weight of up to 1.600 kg
- 3** with lifting adjustment for turning sandwich elements

Working Stands

Application Examples and Details



VacuStand VS-I with pneumatical swivel attachment for installation of side and back windows on cars



VacuStand for power-independent operation with exchangeable batteries

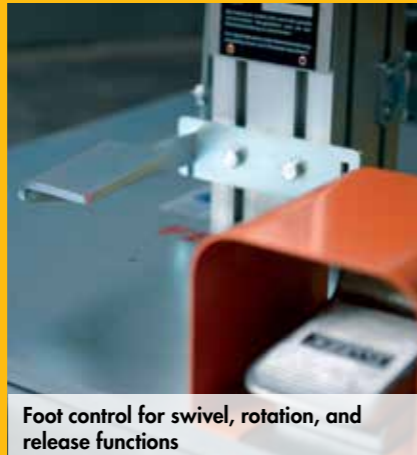

Foot control for swivel, rotation, and release functions



Arrest module for swivelling and rotation motion

VacuStand VS in Action

- 1 VacuStand VS-I in mobile design with battery operation as power-independent assembly aid
- 2 Strictly pneumatically working VacuStand VS-I with ejector and pneumatical swivel attachment
- 3 VacuStand VS-I with glass pane in swivelled position
- 4 Mobile assembly aid for fenders with exchangeable batteries with electrical height and swivel attachment

Working Stands

Mobilift ML

Mobile Working Stand with Lift Drive up to 200 kg

The new mobile working stands with lift drive have smooth load castors which allow an exact positioning of the device. By means of a rocking lever loads can be easily and comfortably lifted or lowered. Additionally the Mobilift devices can be equipped with vacuum technology and different movement axes; thus special handling operations can be carried out in a simpler and more rational way.

- Lifting aid for loads of all kinds
- Commissioning of workpieces
- Simple assembly aid
- Upgradeable with vacuum technology and different movement axes

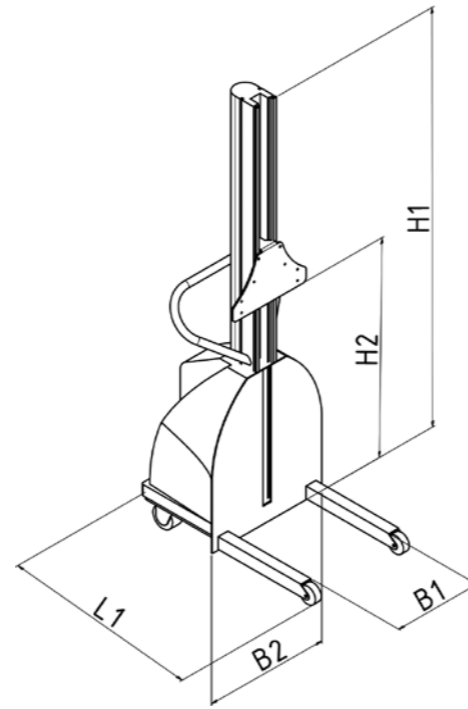

Capacity (kg)	Type	Stroke H2 (mm)	Stroke (m/min)	Battery (VDC/Ah)	B1 (mm)	B2 (mm)	L1 (mm)	H1 (mm)	Own weight (kg)
100	MBL-125	80 ... 1.500	2	2x12 / 17	560	500	985	1.920	80
200	MBL-200	80 ... 1.500	2	2x12 / 40	560	500	985	1.920	100

Mobilift ML in Action

- 1 Mobilift for loading a welding machine with metal form parts
- 2 Handling of cover sheets with integrated vacuum technology and rotation attachment
- 3 Mobilift with integrated vacuum technology for fixation of steel containers